

INSTALLATION MANUAL

BACKUP HEATER

Please read this installation manual completely before installing the product. Installation work must be performed in accordance with the national wiring standards by authorized personnel only. Please retain this installation manual for future reference after reading it thoroughly.

Original instruction

THERMA V™ (Backup Heater, Electric Heater Accessory)



MFL68681815
Rev.03_012521

SAFETY PRECAUTIONS

To prevent injury to the user or other people and property damage, the following instructions must be followed.

- Be sure to read before installing the unit.
- Be sure to observe the cautions specified here as they include important items related to safety.
- Incorrect operation due to ignoring instruction will cause harm or damage. The seriousness is classified by the following indications.

WARNING

This symbol indicates the possibility of death or serious injury.

CAUTION

This symbol indicates the possibility of injury or damage to properties only.

WARNING

Installation

- Do not use a defective or underrated circuit breaker. Use this appliance on a dedicated circuit.
 - There is risk of fire or electric shock.
- For electrical work, contact the dealer, seller, a qualified electrician, or an Authorized Service Center.
 - There is risk of fire or electric shock.
- Always ground the unit.
 - There is risk of fire or electric shock.
- Install the panel and the cover of control box securely.
 - There is risk of fire or electric shock.
- Always install a dedicated circuit and breaker.
 - Improper wiring or installation may cause fire or electric shock
- Use the correctly rated breaker or fuse.
 - There is risk of fire or electric.
- Do not modify or extend the power cable.
 - There is risk of fire or electric shock.
- Do not install, remove, or reinstall the unit by yourself (customer).
 - There is risk of fire, electric shock, explosion, or injury.

- For antifreeze, always contact the dealer or an authorized service center.
 - Almost the antifreeze is a toxic product.
- For installation, always contact the dealer or an authorized Service Center.
 - There is risk of fire, electric shock, explosion, or injury.
- Do not install the unit on a defective installation stand.
 - It may cause injury, accident, or damage to the unit.
- Be sure the installation area does not deteriorate with age.
 - If the base collapses, the unit could fall with it, causing property damage, unit failure, and personal injury.
- Do not install the water pipe system as Open loop type.
 - It may cause failure of unit.
- Make sure the connected condition of connector in product after maintenance.
 - Otherwise, it may cause product damage.

Operation

- Take care to ensure that power cable could not be pulled out or damaged during operation.
 - There is risk of fire or electric shock.
- Do not place anything on the power cable.
 - There is risk of fire or electric shock.
- Do not plug or unplug the power supply plug during operation.
 - There is risk of fire or electric shock.
- Do not touch (operate) the unit with wet hands.
 - There is risk of fire or electric shock.
- Do not place a heater or other appliances near the power cable.
 - There is risk of fire or electric shock.
- Do not allow water to run into electric parts.
 - There is risk of fire, failure of the unit, or electric shock.
- Do not store or use flammable gas or combustibles near the unit.
 - There is risk of fire or failure of unit.
- Do not use the unit in a tightly closed space for a long time.
 - It may cause damage to the unit, when flammable gas leaks.
- If strange sounds, smell or smoke comes from unit, turn the breaker off or disconnect the power supply cable.
 - There is risk of electric shock or fire.

- Stop operation and close the window in storm or hurricane. If possible, remove the unit from the window before the hurricane arrives.
 - There is risk of property damage, failure of unit, or electric shock.
- Do not open the front cover of the unit while operation. (Do not touch the electrostatic filter, if the unit is so equipped.)
 - There is risk of physical injury, electric shock, or unit failure.
- Do not touch any electric part with wet hands. you should be power off before touching electric part.
 - There is risk of electric shock or fire.
- If you touch the pipe or internal parts, you should be wear protection or wait time to return to normal temperature.
 - Otherwise , it may cause burns or frostbite, personal injury.
- Do not touch electric parts for 10 minutes after main power off.
 - There is risk of physical injury, electric shock.
- When the unit is soaked (flooded or submerged), contact an Authorized Service Center.
 - There is risk of fire or electric shock.
- Be cautious that water could not be poured to the unit directly.
 - There is risk of fire, electric shock, or unit damage.
- Turn the main power off when cleaning or maintaining the unit.
 - There is risk of electric shock.
- Take care to ensure that nobody could step on or fall onto the unit.
 - This could result in personal injury and unit damage.
- For installation, always contact the dealer or an Authorized Service Center.
 - There is risk of fire, electric shock, explosion, or injury.

CAUTION

Installation

- Keep level even when installing the unit.
 - To avoid vibration or water leakage.
- Use two or more people to lift and transport the unit.
 - To avoid personal injury.
- Do not install the unit in potentially explosive atmospheres.

Operation

- Do not use the unit for special purposes, such as preserving foods, works of art, etc.
 - There is risk of damage or loss of property.

- Use a soft cloth to clean. Do not use harsh detergents, solvents, etc.
 - There is risk of fire, electric shock, or damage to the plastic parts of the unit.
- Do not step on or put anything on the unit.
 - There is risk of personal injury and failure of unit.
- Use a firm stool or ladder when cleaning or maintaining the unit.
 - Be careful and avoid personal injury.
- Do not turn on the breaker or power under condition that front panel cabinet, top cover, control box cover are removed or opened.
 - Otherwise it may cause fire, electric shock, explosion or death.
- This appliance can be used by children aged from 8 years and above and persons with reduced physical, sensory or mental capabilities or lack of experience and knowledge if they have been given supervision or instruction concerning use of the appliance in a safe way and understand the hazards involved. Children shall not play with the appliance. Cleaning and user maintenance shall not be made by children without supervision.
- The appliance shall be disconnected from its power source during service and when replacing parts.
- Means for disconnection must be incorporated in the fixed wiring in accordance with the wiring rules.
- This equipment shall be provided with a supply conductor complying with the national regulation.
- This appliance is not intended for use by persons (including children) with reduced physical, sensory or mental capabilities or lack of experience and knowledge, unless they have been given supervision or instruction concerning use of the appliance by a person responsible for their safety.
Children should be supervised to ensure that they do not play with the appliance.



ENGLISH

Disposal of your old appliance

1. When this crossed-out wheeled bin symbol is attached to a product it means the product is covered by the European Directive 2002/96/EC.
2. All electrical and electronic products should be disposed of separately from the municipal waste stream via designated collection facilities appointed by the government or the local authorities.
3. The correct disposal of your old appliance will help prevent potential negative consequences for the environment and human health.
4. For more detailed information about disposal of your old appliance, please contact your city office, waste disposal service or the shop where you purchased the product.

MODEL INFORMATION

Model number nomenclature

H A 06 1 M E1

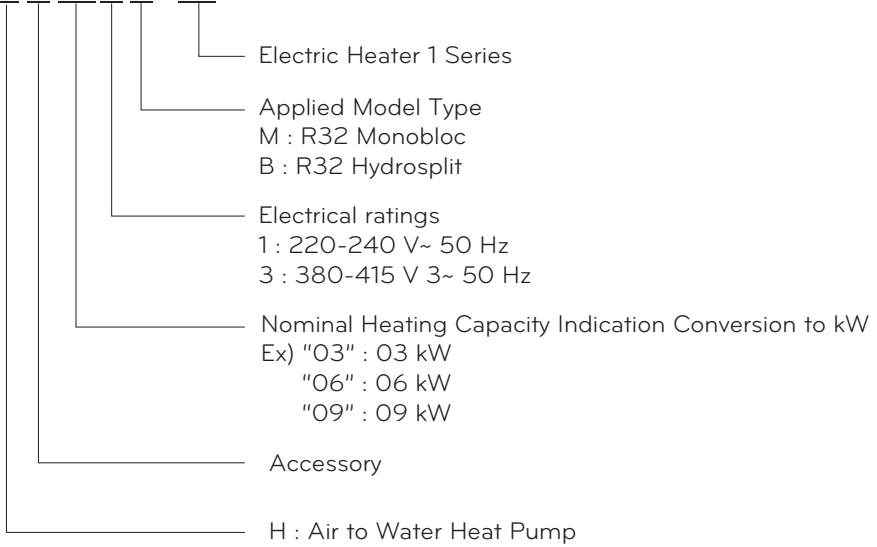







INSTALLATION METHOD





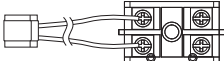

Installation Part

Before starting installation, please make it sure that all parts are found inside the product box.

[BACKUP HEATER For R32 Monobloc]

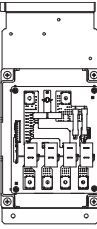
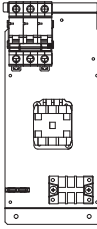
Item	Image	Quantity
Backup Heater		1
Installation Manual		1
Owner's / Installation Manual		1
Installation Sheet		1
Terminal Block KIT		1
Screw		1

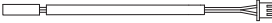
[BACKUP HEATER For Hydrosplit]

Item	Image		Quantity
	1Ø	3Ø	
Backup Heater			1
Installation Manual			1
Owner's / Installation Manual			1
Control Panel			1
Circuit Breaker		N/A	1
Screw			3
Temperature Sensor			1
Middle Link Harness			1

Maintenance

To assure best performance of Backup Heater, it is required to perform periodical check and maintenance. It is recommended to proceed following check list for once a year.



CAUTION

- Turn off the power before proceeding maintenance.

No	Category	Item	Check Point
1	Water	Water pressure	<ul style="list-style-type: none"> • In normal state, the pressure gage (in front of the indoor unit) should indicate 2.0~2.5 bar. • If the pressure is less than 0.3 bar, please recharge the water.
2	Electricity	Terminal block wiring	<ul style="list-style-type: none"> • Look and inspect if there is loosen or defected connection on the terminal block.



CAUTION

- Electric Heater has to be installed vertically like the below figure.



WARNING

Followings should be kept before installation.

- Main power must be turned off during installing 3rd party accessories.
- 3rd party accessories should be comply with supported specification.
- Proper tools should be chosen for installation.
- Never do installation with wet hands.

General Information

Electric Heater is supported by LG Electronics.

Applied Model	Phase	Capacity (kW)	Power Source
R32 Monobloc	1Ø	3	220-240 V ~ 50 Hz
		6	
	3Ø	6	380-415 V ~ 50 Hz
Hydrosplit	1Ø	6	220~240 V ~ 50 Hz
	3Ø	6	380~415 V ~ 50 Hz

BACKUP HEATER For R32 Monobloc

Electric Heater is installed on the outside of the unit. It is recommended to install it in the indoor.

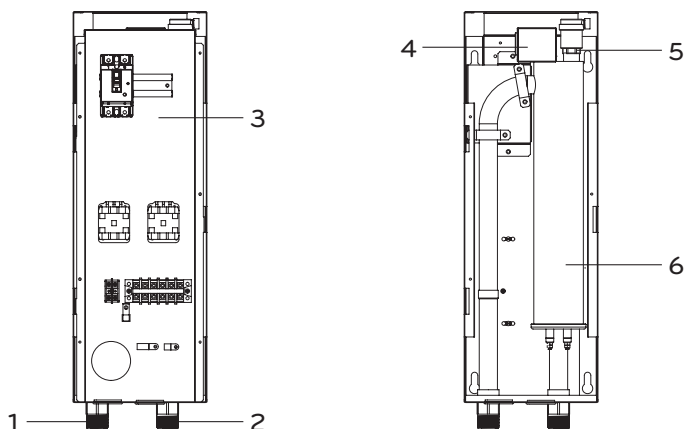

Description

No	Name	Remark
1	Leaving Water Pipe	Male PT 1 inch
2	Entering Water Pipe	Male PT 1 inch
3	Control Box	Terminal blocks, Magnetic switch, Circuit breaker
4	Thermal switch	Cut-off power input to electric heater at 90 °C (manual return at 55°C)
5	Air vent	Air purging when charging water
6	Electric Heater	

BACKUP HEATER For Hydrosplit

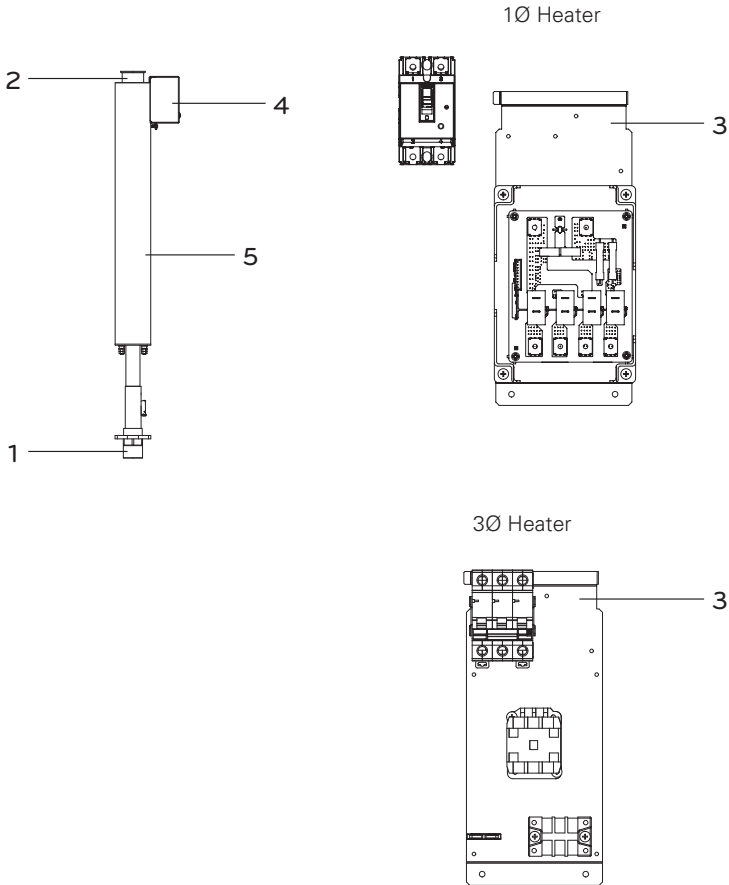

Description

No	Name	Remark
1	Leaving Water Pipe	Male PT 1 inch
2	Entering Water Pipe	
3	Control Panel	1Ø : PCB Assembly, Circuit breaker 3Ø : Terminal block, Magnetic switch, Circuit breaker
4	Thermal switch	Cut-off power input to electric heater at 90 °C (manual return at 55°C)
5	Electric Heater	

! CAUTION

- If water inlet temperature is above 65 °C, the unit does not operated for the sake of system protection.
- If water inlet temperature is below 5 °C, the unit does not operated for the sake of system protection. Wait while unit warms up the water inlet temperature.
- Safety valve opens at water pressure 3 bar. After water charging, the pressure gage (in front of the indoor unit) should indicate 2.0~2.5 bar. Do not exceed 3.0 bar.

General Considerations

Followings are should be considered before the installation of the Backup Heater.

- The installation place should be free from outdoor weather conditions such as rain, snow, wind, frost, etc.
- Choose the place where is water-resistant or good drainage.
- Service space should be secured.
- No flammable materials around the indoor unit.
- Mice can not be appeared to prevent entering the indoor unit or attacking wires.
- Do not place anything in front of the indoor unit to ensure air circulation around the indoor unit.
- Do not locate anything under the indoor unit to be free from unexpected water out.
- In case of water pressure increasing to 3 bar, water drainage should be treated when water is drained by safety valve.

Service Space

(BACKUP HEATER for R32 Monobloc)

- Ensure that the spaces indicated by arrows around bottom, side, and top side.
- Wider spaces are preferred for easy maintenance and piping.
- If minimum service space is not secured, air circulation can be troubled and internal parts of the indoor unit can be damaged by overheating.
- Maximum length of pipe between the Backup Heater and unit is 10 m.

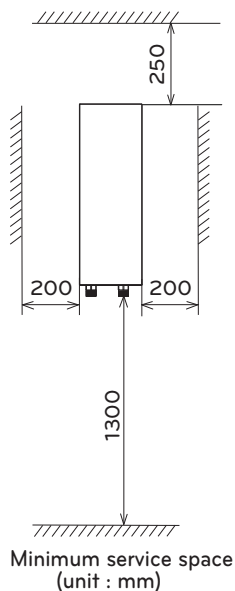

Mounting on the Wall (BACKUP HEATER For R32 Monobloc)

Step 1. Uncover the electric heater accessory.

Step 2. Attach "Installation Sheet" to the wall and mark the location of bolts. This sheet helps to find correct location to the bolts.(Installation Sheet is included in Backup Heater Front Panel.)

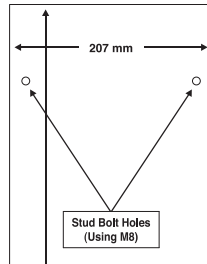

⚠ CAUTION

- The sheet should be attached level. If not, the supporting plate and the indoor unit will not be mounted correctly.

Step 3. Screw bolts at the hole marks.

When screwing bolts, use M8 anchor bolts to secure hanging the unit.

Step 4. Fasten the electric heater accessory on the wall.

⚠ CAUTION

- Electric Heater must be located highest level of water pipe system.
(Because air vent is added in electric heater accessory.)

How to Pipe Electric Heater

Follow below procedures Step 1 ~ Step 4.

Step 1. Uncover the electric heater accessory.

Step 2. Check the diameter of pre-installed pipes of unit.

Step 3. If the diameter of pre-installed pipes is different from diameter of electric heater accessory kit, it is necessary to reduce or extend pipe's diameter.

Step 4. Connect the pipes. The inlet pipe of electric heater accessory must be connected to outlet of the unit.

※ In R32 Hydrosplit, Connect the pipe to the heater using the pipe previously used in the indoor unit.

WARNING

Followings should be kept before installation.

- The unit should be stop before the piping work.
- Never connect electric power while piping electric heater.
- Before the piping working, water in the part(or to heating loop) installed with electric heater should be drained. After working, water should be charged.

CAUTION

- Electric Heater should be installed with enough space for installation and service.
- Water pipes and connections should be cleaned using water.
- Methods to prevent leakage in plumbing connections must be applied.
- Heater must not be impacted.
- Do not let dirty particle be dropped inside tank to avoid possibility of degrade.
- After installation, make it sure that no leakage is appeared in the connection.

How to install Backup Heater for Hydrosplit

Follow below procedures Step 1 ~ Step 7.

Step 1. Disconnect the remote control case from the front panel and disconnect the remote control cable.

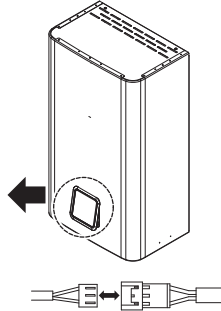

Step 2. Loosen the screws and remove the front panel from the indoor unit. Hold left and right while removing the front panel upwards.

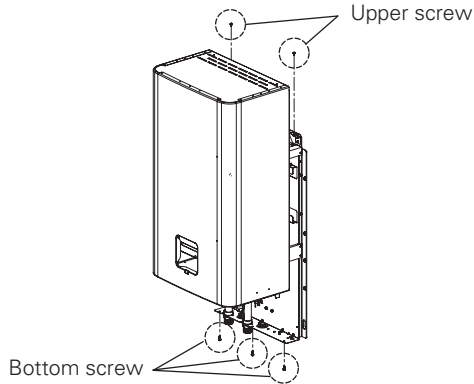

Step 3. Remove the securing parts (screws, clip) of the indoor unit water pipe and separate the water pipe.

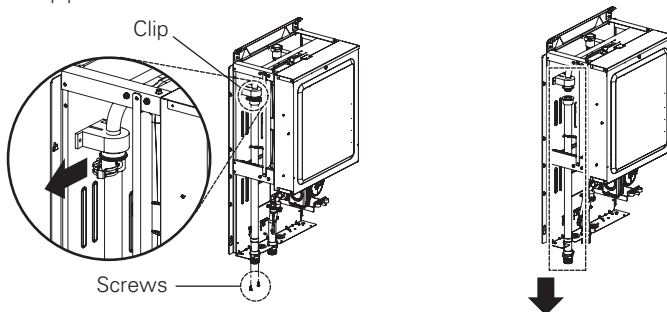

Step 4. Equip the BACKUP HEATER and fasten the securing parts(screws, clip) that were removed in step 3. Connect earth wire of Heater to the base panel using a screw as shown below.

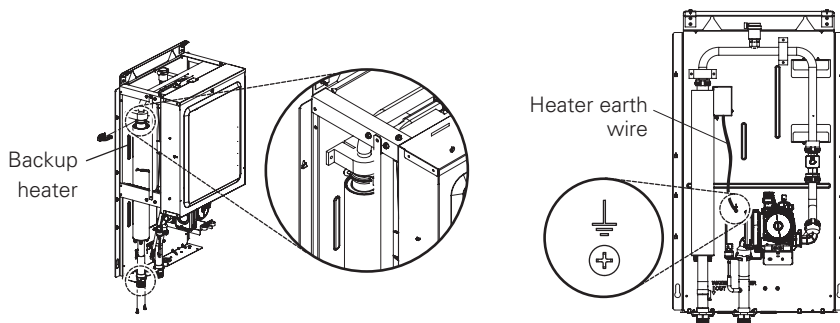

Step 5. Loosen the screws, then release the cover from the control box.

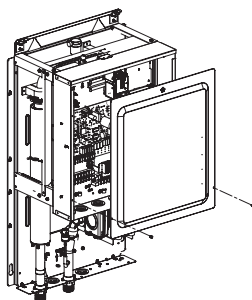

Step 6. Equip the BACKUP HEATER control panel assembly onto the control box as shown below. Hang the control panel on the hook.

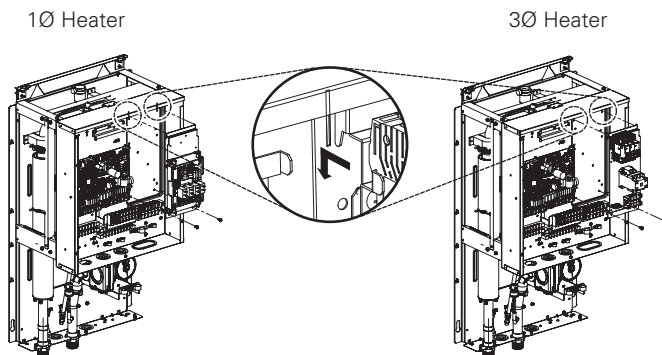

Step 7. For 1Ø Heater, Loosen the screw to separate the ground wire of the main PCB, and connect the ground wire of the main PCB and the ground wire of the heater PCB to the control box at the same time using a screw. Then mount the circuit breaker to the DIN Rail Bracket.

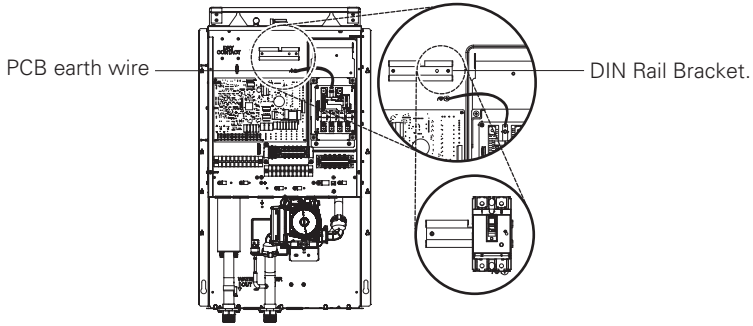

Terminal Block Information

Symbols used below pictures are as follows :

- L, L1, L2 : Live (230 V AC)
- N : Neutral (230 V AC)
- BR : Brown , WH : White , BL : Blue , BK : Black

(Backup Heater for R32 Monobloc)

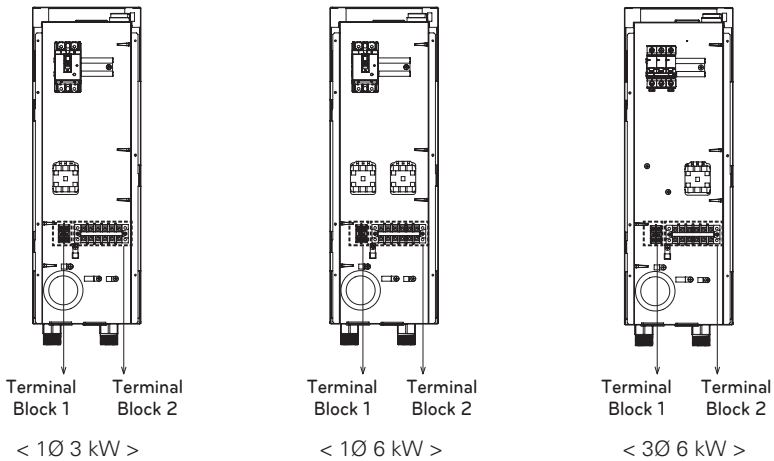

(Backup Heater for Hydrosplit)

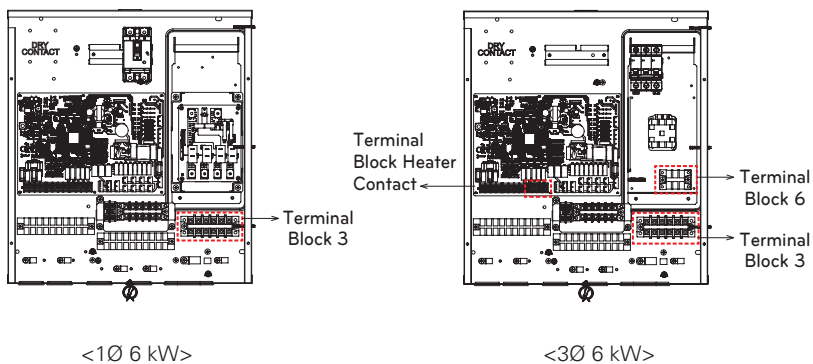

How to Connect Sensor to Unit

(Backup Heater for R32 Monobloc)

- ① Find Backup Heater Terminal Block KIT.
- ② Install the Terminal Block KIT after checking the hole for screw.
- ③ Plug it to 'E/Heater Out' (White Connector) of CN_TH3 in the Main PCB (Unit).
- ④ Connect cable between the unit and the Backup Heater.
- ⑤ Use the cord clamper to fix the cable through low voltage hole.

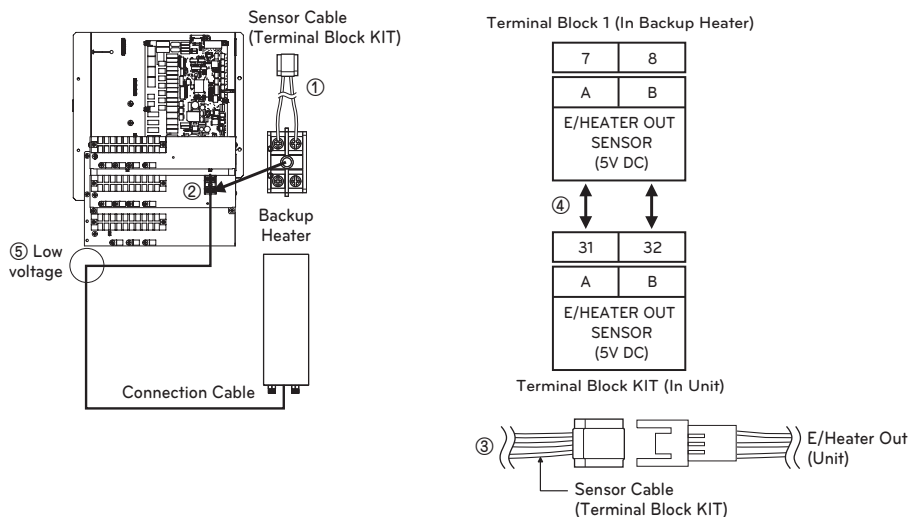

How to Connect the Sensor to Indoor Unit (Backup Heater for Hydrosplit)

- ① Find the Temperature sensor and Middle Link Harness.
- ② Insert connector(White) of the temperature sensor to connector(White) of the middle link harness as shown below.

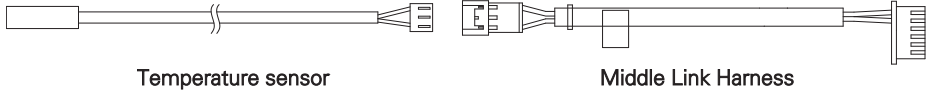

- ③ Insert connector(Black) of the middle link harness into 'CN_TH3' in the Main PCB connector(Black) as shown below. The sensor should be mounted correctly to outlet pipe of backup heater as shown below.

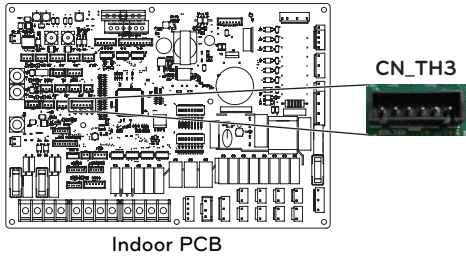

Outlet Pipe of Heater

How to Wire Electric Heater (BACKUP HEATER for R32 Monobloc)

Follow below procedures Step 1 ~ Step 4.

Step 1. Uncover the electric heater accessory.

Step 2. Find the terminal block and connect wires.
(Wires are field-supplied item.)

Step 3. Connect terminal block ports of unit and electric heater accessory.

(1Ø 3 kW)

Terminal Block 2 (In Backup Heater)

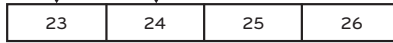
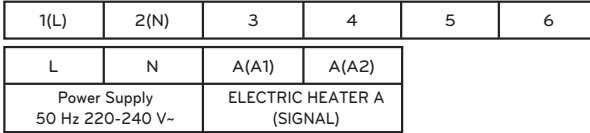

Terminal Block 3 (In Unit)

(1Ø 6 kW)

Terminal Block 2 (In Backup Heater)

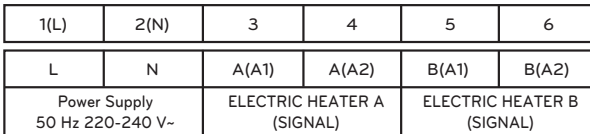

Terminal Block 3 (In Unit)

(3Ø 6 kW)

Terminal Block 2 (In Backup Heater)

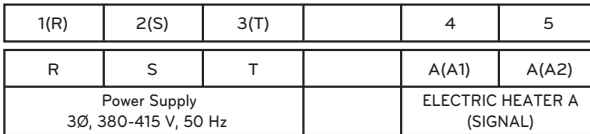

Terminal Block 3 (In Unit)

Step 4. Connect power supply cable to terminal block 2.

Terminal Block 2 (In 1Ø Backup Heater)

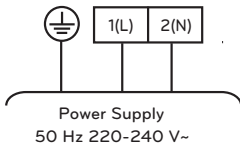

Terminal Block 2 (In 3Ø Backup Heater)

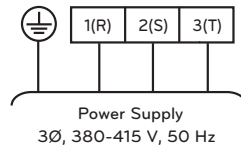

How to Wire Electric Heater (For Hydrosplit 1Ø Backup heater)

Follow below procedures Step 1 ~ Step 5.

Step 1. Uncover the control panel and equip BACKUP HEATER Control panel assembly.
Refer to "Installation Step 5."

Step 2. Find the Thermal switch wire (Ⓐ, Ⓑ), circuit breaker wire (Ⓒ) and connect terminal block and circuit breaker port of the indoor unit.
Check Symbol Ⓐ "Short wire" and Symbol Ⓑ "Long wire".

Step 3. Find the "BK" wire and "WH" wire and connect circuit breaker port of the indoor unit.

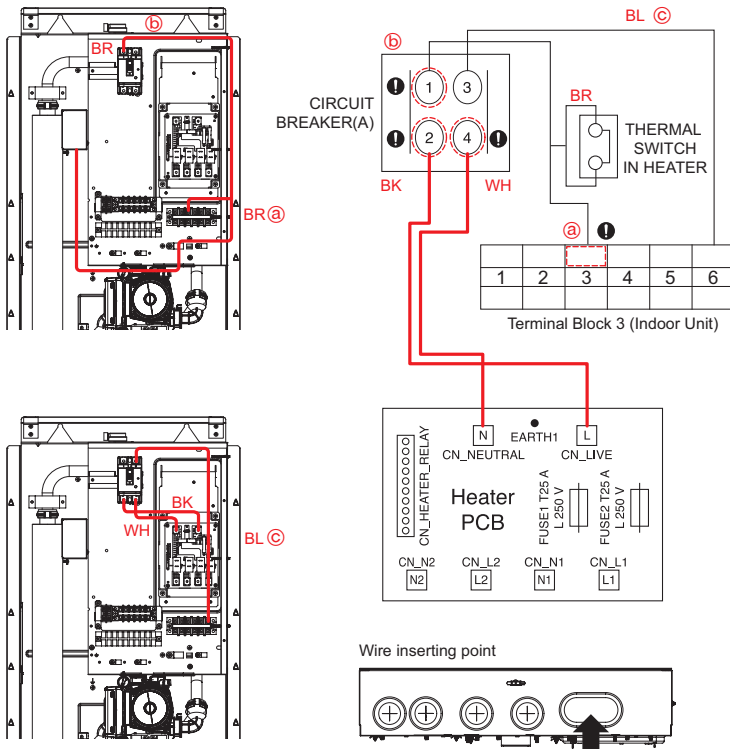

Step 4. Find the heater wire and connect terminal block port of the indoor unit

- Insert Label A connector of Heater into the Label A connector of PCB.
- Insert Label B connector of Heater into the Label B connector of PCB.
- Connect Heater PCB Wire(Symbol @) to CN_HEATER_MAIN In Indoor unit PCB.
- Use clamp to prevent unintended move of wires.

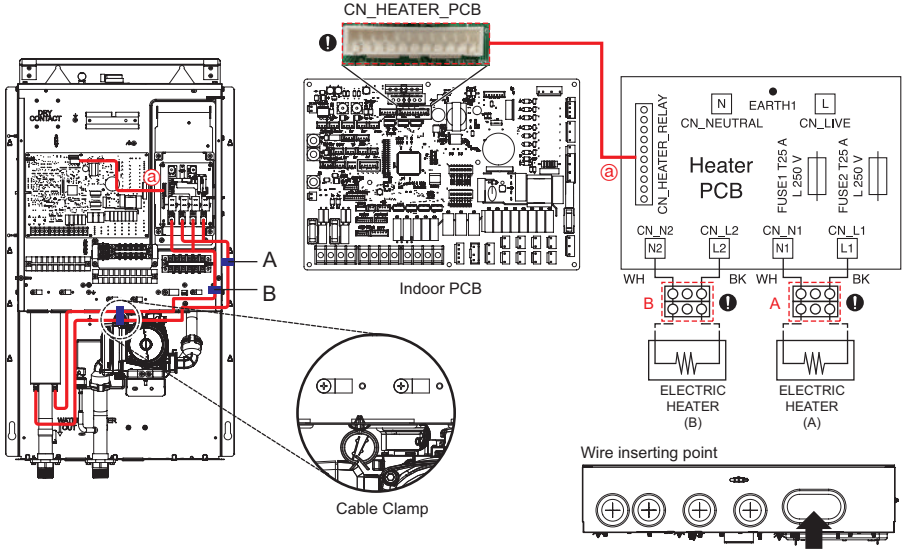

Step 5. Connect power supply cable to terminal block.

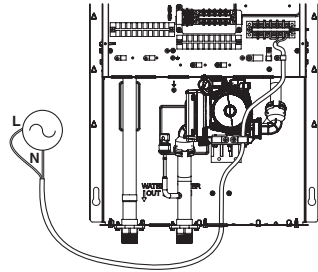
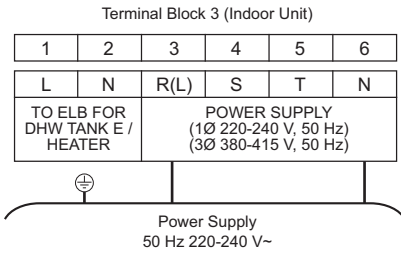

How to Wire Electric Heater (3Ø Backup heater for Hydrosplit)

Follow below procedures Step 1 ~ 7.

Step 1. Uncover the control panel and equip BACKUP HEATER Control panel assembly.
Refer to "Installation Step 5."

Step 2. Find the wires at Terminal block 6 and Connect to Terminal block 3 of indoor unit as show below.

Step 3. Find the wires at Circuit Breaker(C) and connect to Terminal block 3 of indoor unit as show below.
Use clamps to prevent unintended move of wires.
Connect all "BR" wires at the same time.

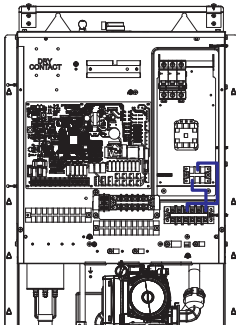

Terminal block 6 (In 3Ø Backup Heater)

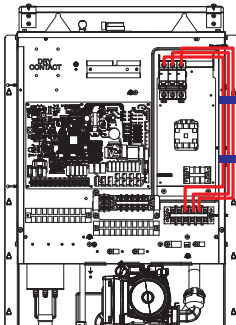
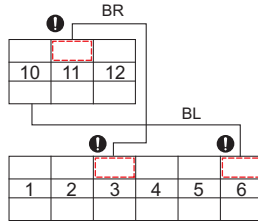

CIRCUIT BREAKER (C)

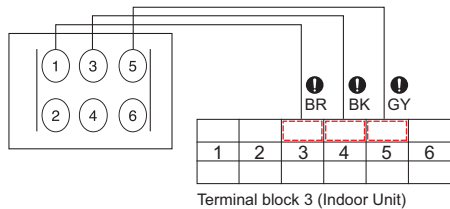

Step 4. Find the wires at Magnetic Contractor **(a)** and **(b)** Terminal block 6.
 Connect to Terminal block in Indoor PCB unit as shown below.
 Check Symbol **(a)** "HEATER1" Label and Symbol **(b)** "COMMON" label.

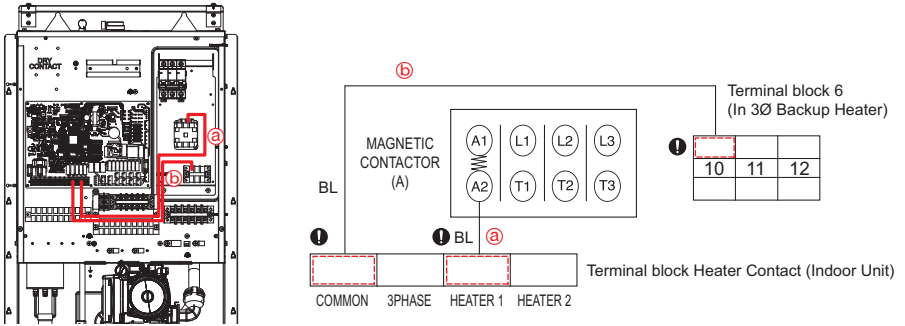

Step 5. Insert the connector(WH) of Thermal Switch Wire into the connector(WH) of terminal block 6 as shown below.

CAUTION

- The connection must be made within the C/Box.

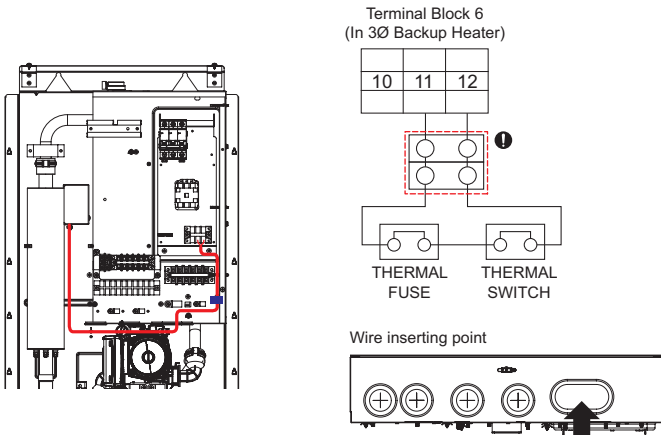

Step 6. Insert the connector 'B' of Circuit Breaker(C) to the connector 'B' of E/Heater and insert the connector 'A' of Magnetic Contactor(A) to the connector 'A' of E/Heater as shown below.

Use cable clamps (or cord clamps) to prevent unintended move of Power cable and Connecting cable.

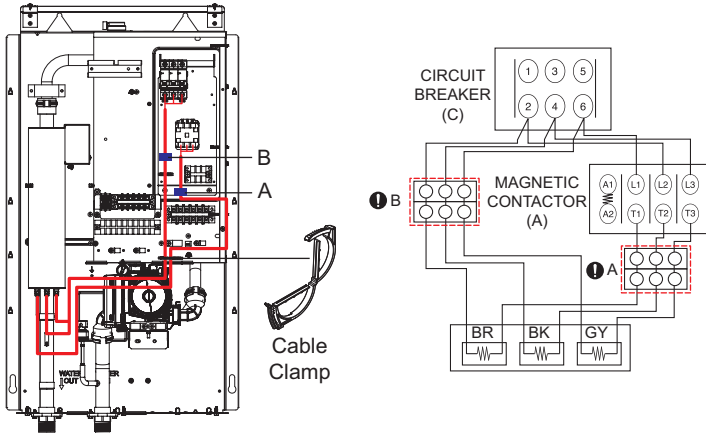

Step 7. Connect power supply cable to terminal block.

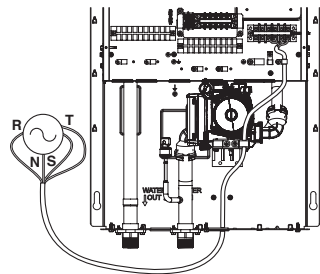
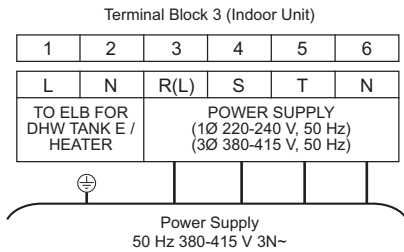

Typical Installation Example (Backup heater for Monobloc)

Floor + Backup Heater (Only Heating)

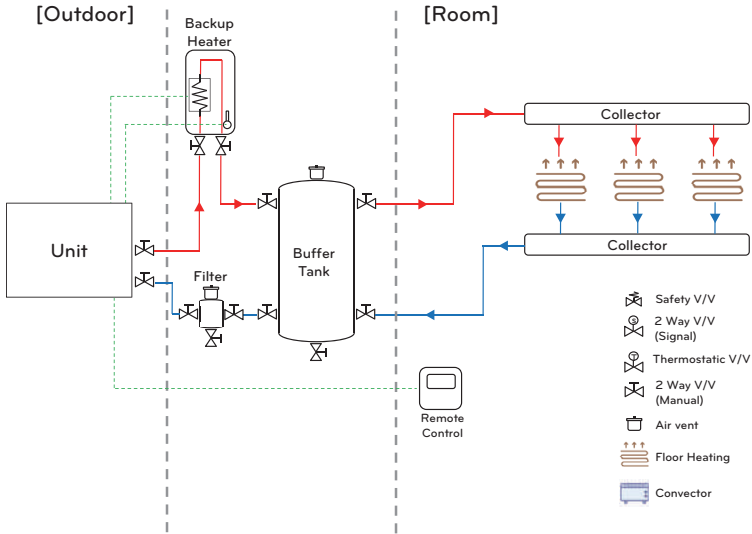

Floor + Convactor + Backup Heater (Heating + Cooling)

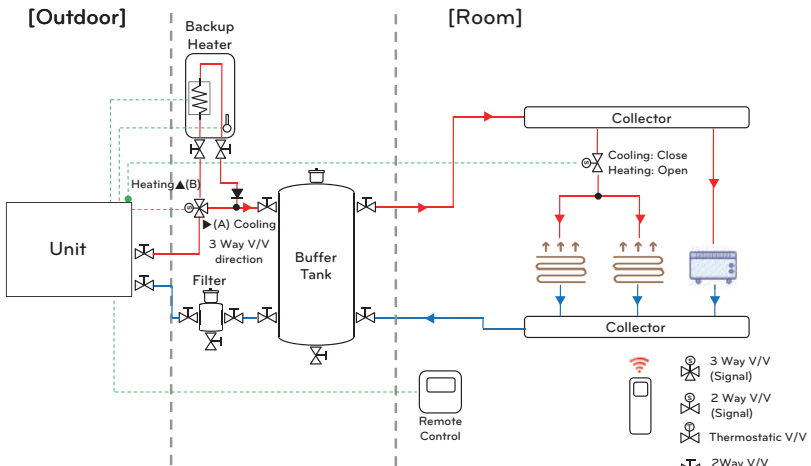

NOTICE

1. When the Backup Heater is installed in a reversible system, condensation may occur inside the Backup Heater.
2. To provide a bypass for the condensate, install 3way valve.

Typical Installation Example (Backup heater for Hydrosplit)

Floor + Backup Heater (Only Heating)

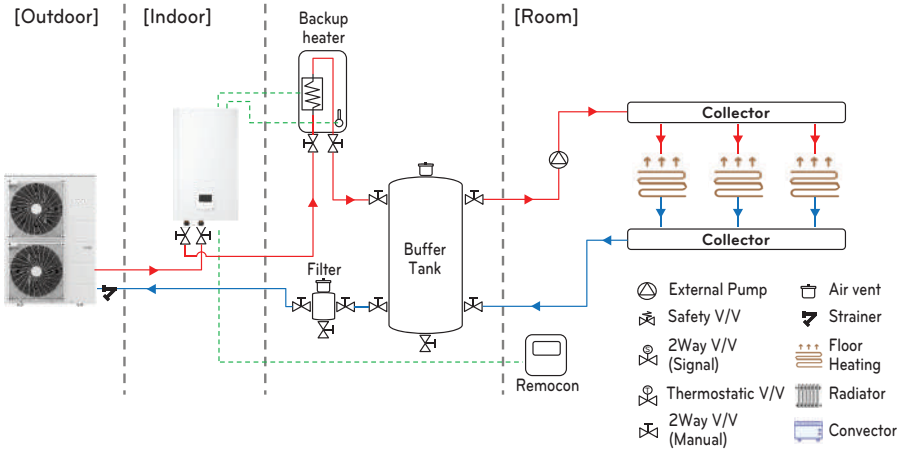

Floor + Convactor + Backup Heater (Heating + Cooling)

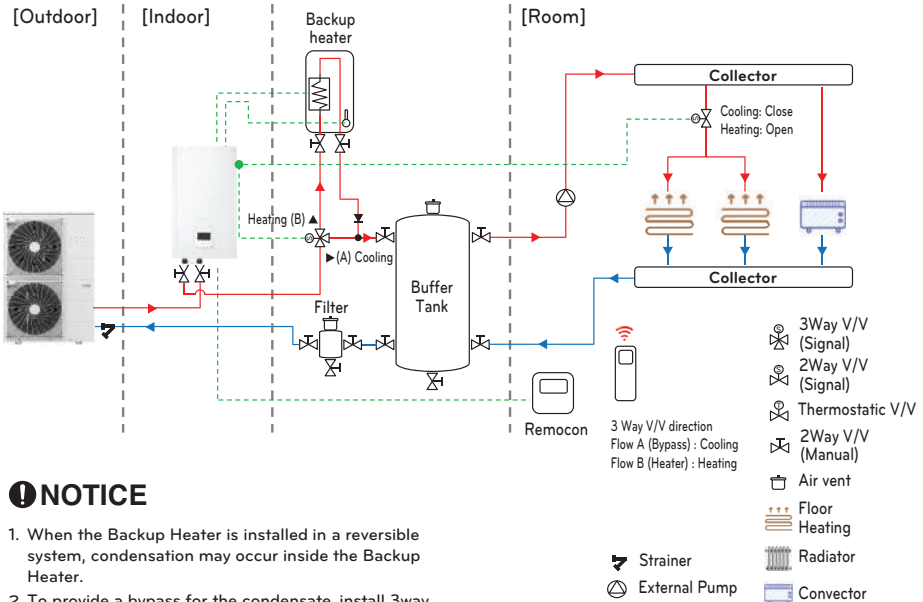

NOTICE

- When the Backup Heater is installed in a reversible system, condensation may occur inside the Backup Heater.
- To provide a bypass for the condensate, install 3way valve.

3Way Valve (For Backup Heater Bypass)

Follow below procedures Step 1 ~ Step 2.

Step 1. Uncover front cover of the unit.

Step 2. Find terminal block and connect wire as below. (in the unit)

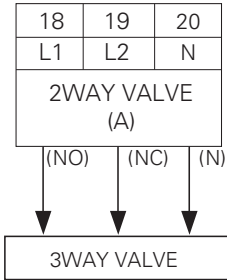

⚠ WARNING

- When type of 2way valve is NO type, 3way valve should select Flow A (bypass) when electric power is supplied to wire (NO) and wire (N).
- When type of 2way valve is NC type, 3way valve should select Flow A (bypass) when electric power is supplied to wire (NC) and wire (N).

⚠ CAUTION

- 3way valve should be connected together with 2way valve in terminal block.
- Keep the distance between 3way valve and Backup Heater more than 0.5m.
- To prevent reverse flow, It is important to use one way valve(check valve) to Backup Heater water outlet.

(1) : Flow A means 'water flow from the unit to Buffer tank.' (Cooling)

(2) : Flow B means 'water flow from the unit to Backup Heater.' (Heating)

Final check

- Flow direction
 - Water should not flow into Heater loop (B) in cooling mode.
 - To verify the flow direction, check temperature at the water inlet of the under floor loop.
 - If correctly wired, this temperatures should not be approached to 6°C in cooling mode.
- Noise or water pipe vibration while 3way valve operation.
 - Due to surging effect or cavitation effect, noise or water pipe vibration can be occurred while 3way valve is operating.
 - In that case, check followings :
 - Is water circuit (both under floor water loop and sanitary water tank loop) fully charged? If not, additional water charging is required.
 - Fast valve operation yields noise and vibration. Appropriated valve operating time is 60~90 seconds.

CAUTION

- **Power Cable Specification :** The power cord connected to the outdoor unit should be complied with IEC 60245 or HD 22.4 S4(Rubber insulated cord, type 60245 IEC 66 or H07RN-F)

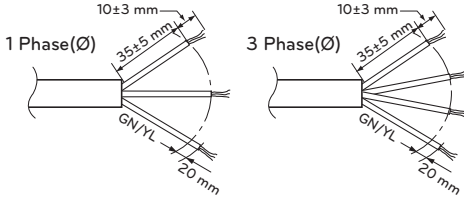

Power Supply	Capacity (kW)	Phase (Ø)	Area (mm ²) x Cores
	3	1	1.5 x 3C
	6		4 x 3C
	6	3	2.5 x 4C

- **Connecting Cable Specification :** The connecting cable connected to the outdoor unit should be complied with IEC 60245 or HD 22.4 S4 (This equipment shall be provided with a cord set complying with the national regulation.)

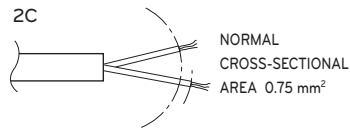
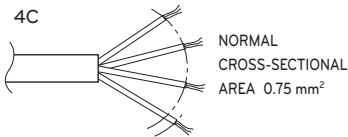

Connecting Cable	Capacity (kW)	Purpose	Phase (Ø)	Area (mm ²) x Cores
	3	SIGNAL (Electric Heater)	1	0.75 x 2C
		Sensor		0.75 x 2C
	6	SIGNAL (Electric Heater)		0.75 x 4C
		Sensor		0.75 x 2C
	6	SIGNAL (Electric Heater)	3	0.75 x 2C
				Sensor

- If the supply cord is damaged, it must be replaced by the manufacturer, its service agent or similarly qualified persons in order to avoid a hazard.
- In order to avoid a hazard due to inadvertent resetting of the thermal cut-out, this appliance must not be supplied through an external switching device, such as a timer, or connected to a circuit that is regularly switched on and off by the utility.

WARNING

Followings should be kept before wiring.

- Supply type of electric heater should be ensured.
- Never connect electric power while wiring electric heater.
- The wire that is connected to electric heater should be used to meet specification of each country.
- Main power of electric heater should be applied with ELCB.

Circuit Breaker Specification

Perform the electrical wiring work according to the electrical wiring connection.

- All wiring must comply with local requirements.
- Select a power source that is capable of supplying the current required by the appliance.
- Pipes and wires should be purchased separately for installation of the product.

Capacity (kW)	Phase (Ø)	ELCB
3	1	20 A
6		40 A
6	3	20 A

DIP Switch Setting (In unit, Heater For R32 Monobloc)

Turn off electric power supply before setting DIP switch.

- Whenever adjusting DIP switch, turn off electric power supply to avoid electric shock.

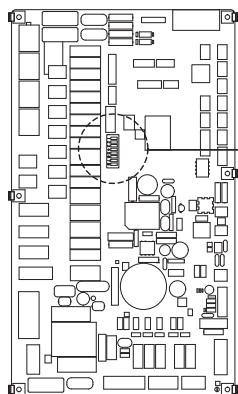

(Unit for R32 Monobloc)

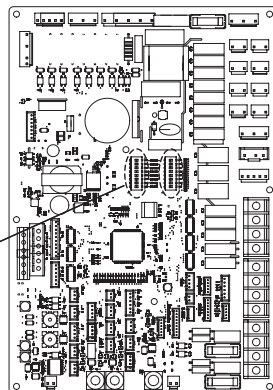
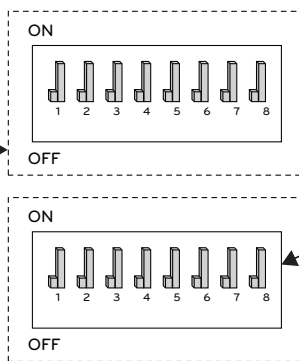

(Indoor Unit for R32 Hydrosplit)

Description	Setting	Default
Selecting electric heater capacity	Electric heater is not used	
	Electric heater is used - Half capacity for 1Ø 6 kW in R32 Monobloc - Full capacity in R32 Hydrosplit	
	Electric heater is not used	
	Full capacity is used - Only for backup heater for R32 Monobloc	

For more information about setting heater on temperature, Please refer to installation manual of unit.



[Representative] LG Electronics Inc. EU Representative : LG Electronics European Shared Service Center B.V. Krijgsman 1, 1186 DM Amstelveen, The Netherlands

[Manufacturer] LG Electronics Inc. Changwon 2nd factory 84, Wanam-ro, Seongsan-gu, Changwon-si, Gyeongsangnam-do, KOREA