

LG

Therma V

Split Type / R32, 50Hz

MFL66101127

TOTAL HVAC SOLUTION PROVIDER

ENGINEERING PRODUCT DATA BOOK

1. Model Line Up

Product	Chassis	Capacity Index	Model Name
		kW	
Split Hydro Box	K1	-	ZHNW09606A1 [HN091MR NK5]
Split IWT	K5		ZHNW20603I1 [HN0913T NK0]

Product	Phase	Chassis	Capacity Index	Model Name	Combination Indoor Unit
			kW		
Split Outdoor Unit	1	U36A	5.5	ZHUW056A0 [HU051MR U44]	ZHNW20603I1 [HN0913T NK0]
					ZHNW09606A1 [HN091MR NK5]
			7.0	ZHUW076A0 [HU071MR U44]	ZHNW20603I1 [HN0913T NK0]
					ZHNW09606A1 [HN091MR NK5]
			9.0	ZHUW096A0 [HU091MR U44]	ZHNW20603I1 [HN0913T NK0]
					ZHNW09606A1 [HN091MR NK5]

* The capacity index may differ from actual capacity values.

Therma V

Split Hydro Box

Split IWT

Split Outdoor Unit

1. ZHNW09606A1 [HN091MR NK5]

1.1 Specifications

Category		Unit	Value
Major	Minor		
Classification	Chassis	-	K1
Current	Current(MAX)	A	0.6
Cooling Operation Range(Leaving Water)	For Fan Coil Unit(Min ~ Max)	°C	5 ~ 27
	For under floor(Min ~ Max)	°C	16 ~ 27
Heating Operation Range(Leaving Water)	Space Heating(Min ~ Max)	°C	15 ~ 65
	Domestic Hot Water(Min ~ Max)	°C	15 ~ 80
Water Pump	Type	-	Canned type for hot water circulation
	Model (Maker,Name)	-	GRUNDFOS(UPM3K 20-75 CHBL)
	Motor type	-	BLDC
	Steps of Pumping Performance	-	10~ 100%(19 Steps)
	Power input(Min~Max)	W	3~60
	Max. Head	m	7.5
Expansion Tank	Volume(Max)	ℓ	8
	Water Pressure(Max)	bar	3
	Water Pressure(Pre-charged)	bar	1
Strainer	Mesh size	mesh	30
	Max. particle size	mm	0.6
	Material	-	STS304
Safety Valve (Water cycle)	Pressure Limit(Upper Limit)	bar	3
Flow Sensor	Type	-	Vortex
	Model (Maker,Name)	-	SIKA VVX20
	Measuring Range (Min~Max)	ℓ/min	5~80
Water Pressure Sensor	Model (Maker,Name)	-	SENSATA
	Measuring Range (Min~Max)	bar(G)	0 ~ 20
Electric Backup Heater	Type	-	Sheath
	Power Supply	V, Φ, Hz	220-240, 1, 50
	Number of Heating Coil	EA	2
	Capacity Combination	kW	3+3
	Heating Steps	Step	2
	Rated Current	A	25.0
	Power Supply Cable(H07RN-F)	mm ² × cores	4.0 x 3C
Heat Exchanger(Refrigerant to Water)	Type	-	Brazed Plate HEX(SWEP, QD20H)
	Quantity	EA	1
	Number of Plate	Sheet	52
	Water Volume	ℓ	0.7
Refrigerant Piping Connection	Liquid	mm(inch)	Φ9.52 (3/8)
	Gas	mm(inch)	Φ15.88 (5/8)
	Connection Type(Liquid)	-	Flare
	Connection Type(Gas)	-	Flare
Water Connecting Pipes	Inlet	inch	Male PT 1" according to ISO 7-1 (tapered pipe threads)
	Outlet	inch	Male PT 1" according to ISO 7-1 (tapered pipe threads)
Sound Power Level	Heating(Rated)	dB(A)	44.0
Dimensions	Net(W x H x D)	mm	490 x 850 x 315
	Shipping(W x H x D)	mm	563×1,082×375
Weight	Net	kg	37.6
	Shipping	kg	43.6
Exterior	Color	-	Noble White
	RAL Code	-	RAL 9016
Connecting Cable	Power and Communication cable(H07RN-F)	mm ² × cores	0.75 x 4C

1. ZHNW09606A1 [HN091MR NK5]

Note

- Due to our policy of innovation some specifications may be changed without notification.
- Wiring cable size must comply with the applicable local and national code. And "Electric characteristics" should be considered for electrical work and design. Especially the power cable and circuit breaker should be selected in accordance with that.
- Sound power level is measured on the rated condition in according with ISO 9614 standard. Therefore, these values depend on the ambient conditions and values are normally higher in actual operation.
- DHW 58~80°C operating is available only when the booster heater is operating.

1. ZHNW09606A1 [HN091MR NK5]

1.2 List of Functions

Category	Functions	Value
Reliability	Self Diagnosis	O
Convenience	Auto Restart	O
	Child Lock	O
	Group Control	X
	Sleep Timer	O
	Turn On/Off Reservation	O
	Schedule	O
	Low Noise Operation	O
Installation	Electric Backup Heater	O
	Domestic Hot Water Tank heater	Accessory(3rd party)
Water Product functions	Anti-Condensation On Floor (cooling)	O
	Water Pump ON / OFF Control	O
	Water Flow Detection	O(by Flow Sensor)
	Water Flow Control	O
	Water Pressure Monitoring	O
	Thermostat Interface (230V AC)	O
	Thermostat Interface (24V AC)	X
	Digital Output For External Pump	O
	Digital input for energy saving (LG ESS/ PV system)	O
	DHW(Domestic Hot Water) Tank Kit	Accessory
	Solarthermal function	Accessory
	PHEX Anti-Freezing Control	O
	Water Pump Forced Operation	O
	Anti-overheating Of Water Pipe	O
	Emergency Operation	O
	Weather Dependent Operation With Thermostat	O
	Weather Compensation For Heating And Cooling (Auto mode)	O
	Scheduler (DHW Tank Heater)	O
	Timer (DHW Tank Heater)	O
	Quick DHW Tank Heating	O
	Screed Drying Mode	O
One Point Dry Contact Input (CN-EXT)	O	
Energy Monitoring	O	
DHW Recirculation	O	
Special Functions	Wi-Fi Control	Accessory
	Modbus connectivity (without gateway)	O
	Remote room temperature sensing	O
	Outdoor Temperature sensing	O
	2nd Circuit / Mixer control	O
	2-Remo control	O

Note

- O : Applied, X : Not Applied
- Accessory : Ordered and purchased separately the accessory package referring to the model name provided and install at field.
- Accessory line-ups varies by region, so check your local catalogue or local sales material.
- Solar thermal system requires the 3rd party accessory, PT-1000 sensor. (field supply)

1. ZHNW09606A1 [HN091MR NK5]

1.3 Accessory Compatibility List

Category	Accessory Name	Model Name	Description	Value
Remote Controller	Wired - RS3 (Standard III)	PREMTW101	White	O
Dry Contact	Simple	PDRYCB000	1 input port, AC 220 - 240V	O
	Communication	PDRYCB320	8 input port, For 3rd Party Thermostat (Analog Input)	O
Integration Device	Remote Temperature sensor	PQRSTA0	-	O
	Group Control wire	PZCWRCG3	Cable Assembly for group control (Y-type cable : 0.25m, cable : 9.6m)	X
ETC	Extension wire	PZCWRC1	Extension wire for IDU-wired remote controller (9.6m)	O
	2-Remo Control wire	PZCWRC2	-	O
	Wi-Fi Modem	PWFMD200	-	O
	Wi-Fi Extension cable	PWYREW000	USB Extension cable : 10 m	O
	Meter Interface	PENKTH000	-	O
Special Kit	Solar-Thermal Interface kit with DHW Tank	PHLLA	Limit Temperature : 96 °C	X
	Indoor Drain Pan	PHDPB	For Split Hydro Box	X
		PHDPC	For Split Hydro Box	O
	DHW tanks (Single coil)	OSHW-200F	200 L	O
		OSHW-300F	300 L	O
		OSHW-500F	500 L	O
	DHW tanks (Double coil)	OSHW-300FD	300 L	O
	DHW tank kit	PHLTA	For Split Hydro Box(except for HN1639 NK3)	O
		PHLTC	For Split Hydro Box(HN1639 NK3)	X
	DHW sensor	PHRSTA0	-	O
	Thermostatic Mixing valve	OSHA-MV	3/4" DN20	O
		OSHA-MV1	1" DN25	O
	3way valve	OSHA-3V	-	O
	2nd Circuit Thermistor	PRSTAT5K10	-	O
	Backup Heater	HA061B E1	1Ø, 6kW (For Hydrosplit, HN1600MB NK0)	X
HA061C E1		1Ø, 6kW (For Hydrosplit, HN1600MC NK1)	X	
HA063B E1		3Ø, 6kW (For Hydrosplit, HN1600MB NK0)	X	
HA063C E1		3Ø, 6kW (For Hydrosplit, HN1600MC NK1)	X	
Cover plate	PDC-HK10	For IWT and Hydro Box Type indoor units	O	

Note

- O: Possible, X: Impossible, -: Unconfirmed or irrelevant, Embedded : Included with product.
- Some advanced functions controlled by individual controller cannot be operated.
- If there is a difference in development time between the product and the remote controller, some functions cannot be operated.
- Meter Interface cannot be connected at the same time with 3rd-party controller.
- If you need more detail, please refer to the Control(BECON) PDB or the manual of product.
(<http://partner.lge.com/global> : Home> Doc.Library> Product > Control(BECON)).

1. ZHNW09606A1 [HN091MR NK5]

1.4 Dimensions

1.4.1 Internal

[Unit: mm]
 Chassis : K1
 P/No. : TBZ37614404_rev.01

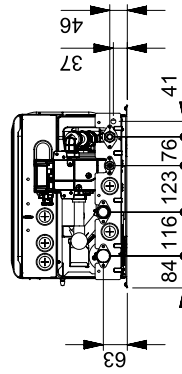
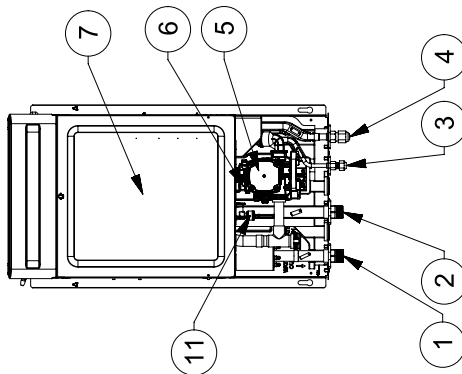
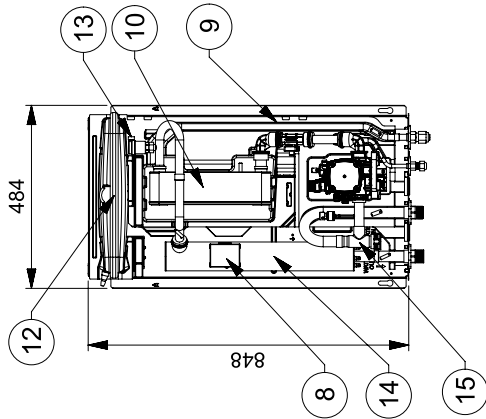
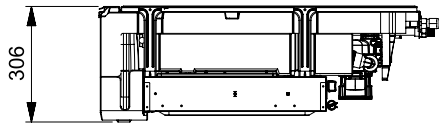

15	Strainer	Filtering and stacking particles inside circulating water
14	Backup Heater	6 kW
13	Air Vent	Air purging when charging water
12	Expansion Tank	Absorbing Volume change of heated water
11	Water Pressure Sensor	SENSATA 2HMP3-04W 0-2MPa
10	Plate Heat Exchanger	Heat exchange between refrigerant and water
9	Flow Sensor	SIKA VVX20 5-80 LPM
8	Thermostat	Cut-off power input to electric heater at 90°C
7	Control Box	PCB and terminal blocks
6	Safety Valve	Open at water pressure 3 bar
5	Water Pump	GRUNDFOS UPM3K 20-75 CHBL
4	Refrigerant Pipe	Ø 15.88 mm
3	Refrigerant Pipe	Ø 9.52 mm
2	Entering Water Pipe	Male PT 1 inch
1	Leaving Water Pipe	Male PT 1 inch
No.	Part Name	Description

1. ZHNW09606A1 [HN091MR NK5]

1.4.2 External

[Unit: mm]
 Chassis : K1
 P./No. : TBZ37614404_rev.01

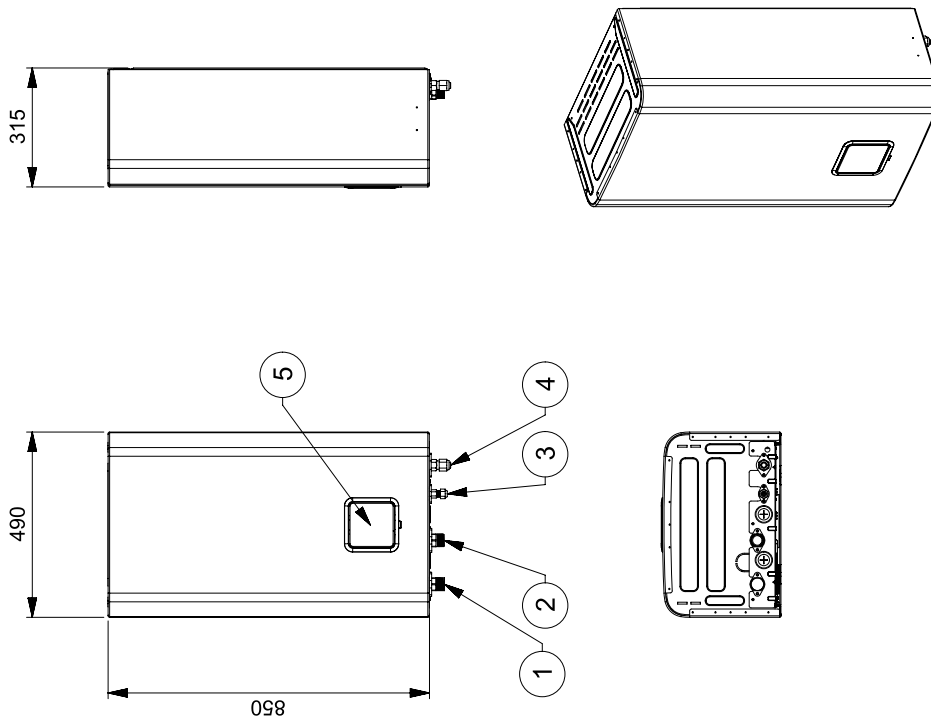

No.	Part Name	Description
5	Control Panel	Built-in Remote Controller
4	Refrigerant Pipe	Ø 15.88 mm
3	Refrigerant Pipe	Ø 9.52 mm
2	Entering Water Pipe	Male PT 1 inch
1	Leaving Water Pipe	Male PT 1 inch
	No. Part Name	Description

1. ZHNW09606A1 [HN091MR NK5]

1.5 Piping Diagrams

1.5.1 Normal

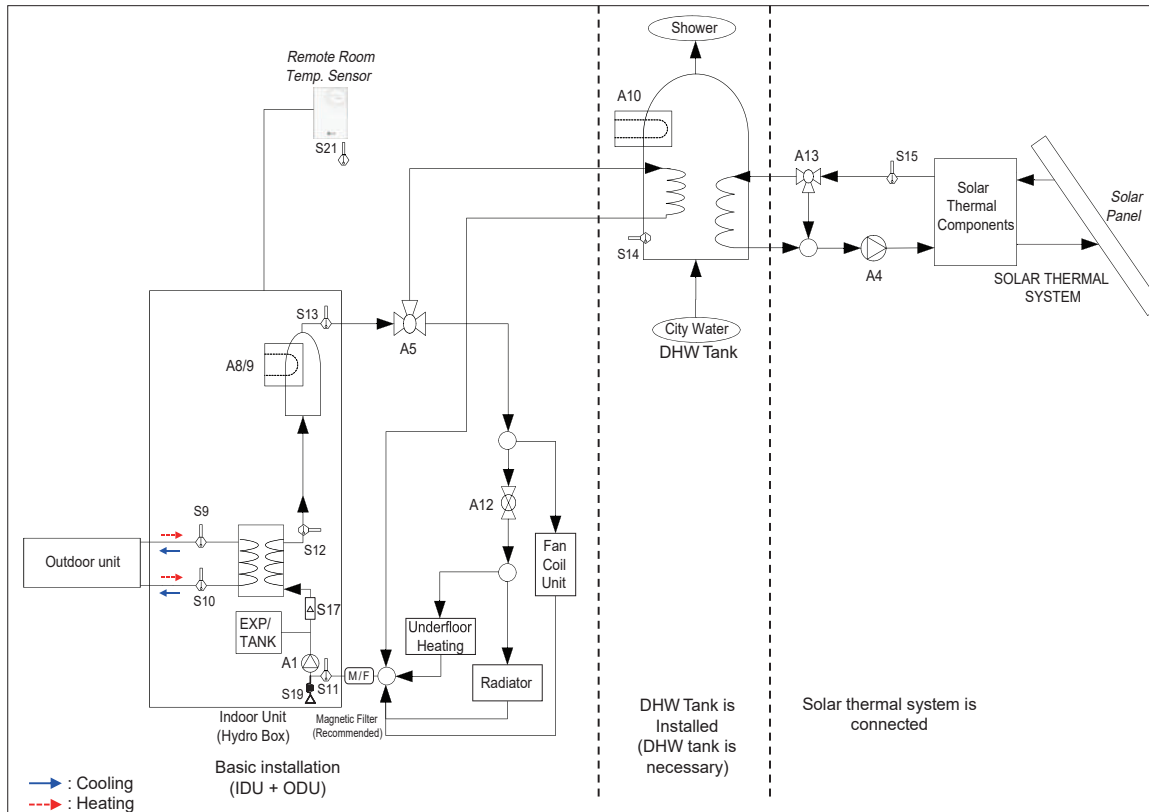

Category	Symbol	Meaning
Indoor unit / Main circuit	S9	Refrigerant temperature sensor (Gas side)
	S10	Refrigerant temperature sensor (Liquid side)
	S11	Entering water temperature sensor
	S12	Leaving water temperature sensor
	S13	Electric backup heater outlet temperature sensor
	S17	Flow Sensor
	S19	Entering Water Pressure sensor
	S20	Reserved
	S21	Remote room air sensor (Direct circuit)
	A1	Internal water pump
	A2	External pump
	A8 / A9	Backup heater (2 steps)
	A12	2-way valve to block underfloor circuit from cooling water
	EXP/TANK	Expansion vessel
	CTR/PNL	Control panel / Remote controller
	M/F	Magnetic filter
Domestic hot water circuit	S14	DHW tank temperature
	A5	3-way valve for changing between heating(cooling) and DHW tank
	A10	DHW boost heater
	W/TANK	Domestic hot water tank
	A15	Reserved
Solar thermal circuit	S23	Reserved
	S15	Solar collector sensor (Field supply, PT-1000)
	S16	Reserved
	A4	Solar collector pump
	A13	3way-valve Solar
	Solar thermal system	Solar thermal equipment such as collector, solar pump, PT1000 sensor, solar heat-exchanger

1. ZHNW09606A1 [HN091MR NK5]

1.6 Wiring Diagrams

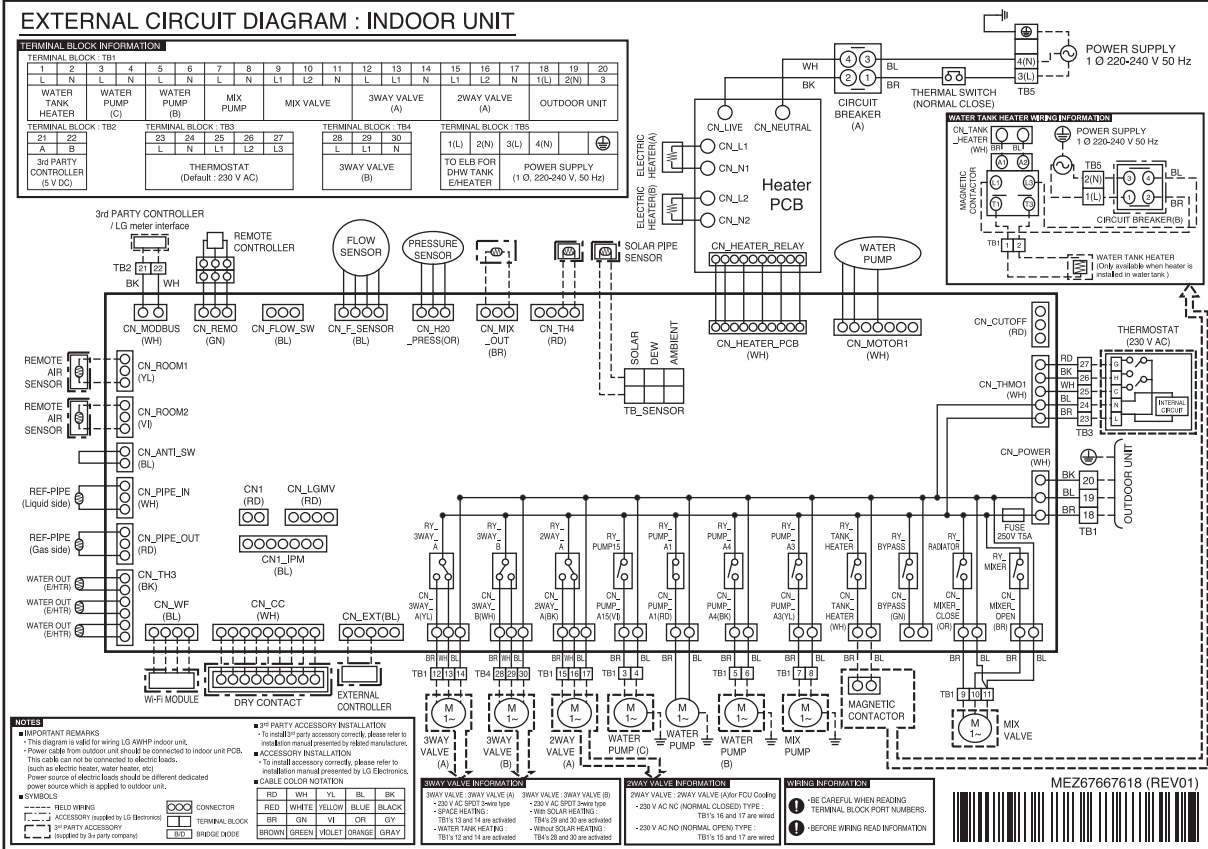
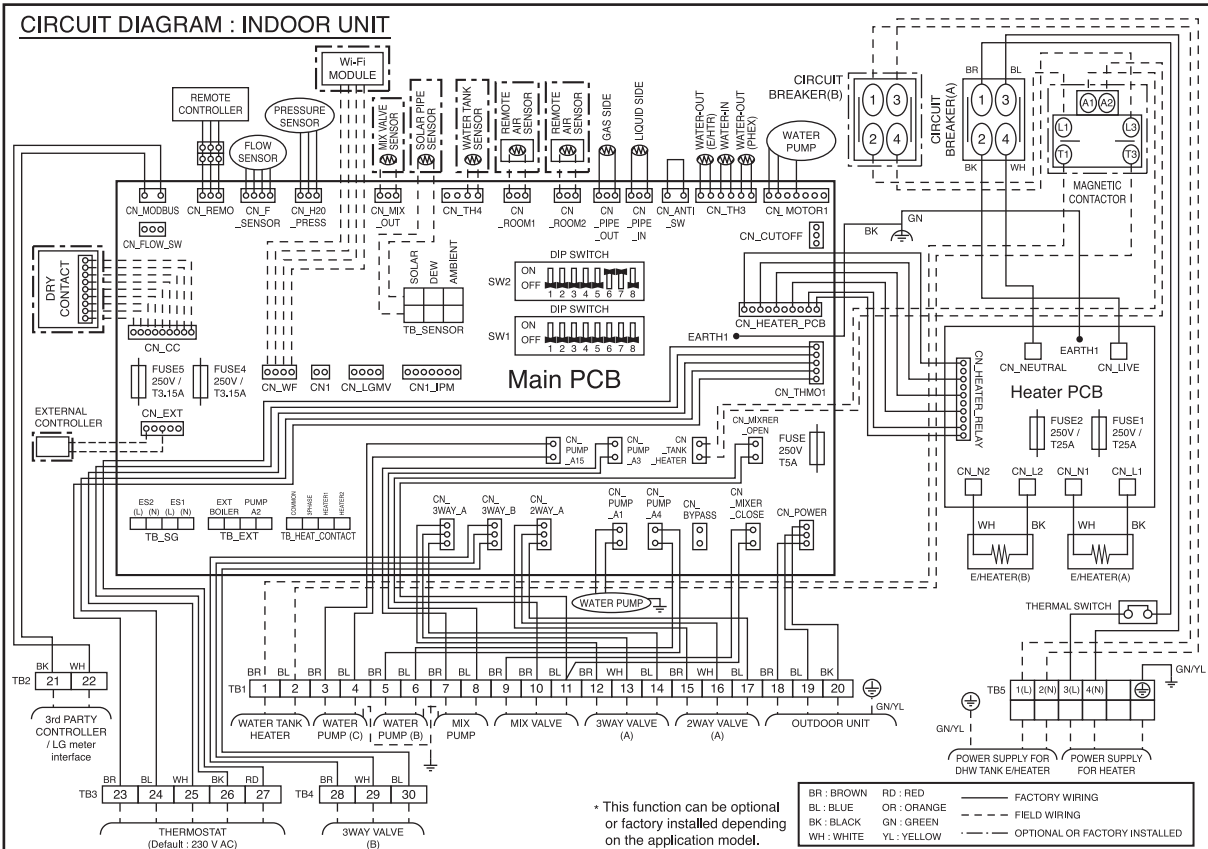

1. ZHNW09606A1 [HN091MR NK5]

1.7 Sound Levels

1.7.1 Power Levels

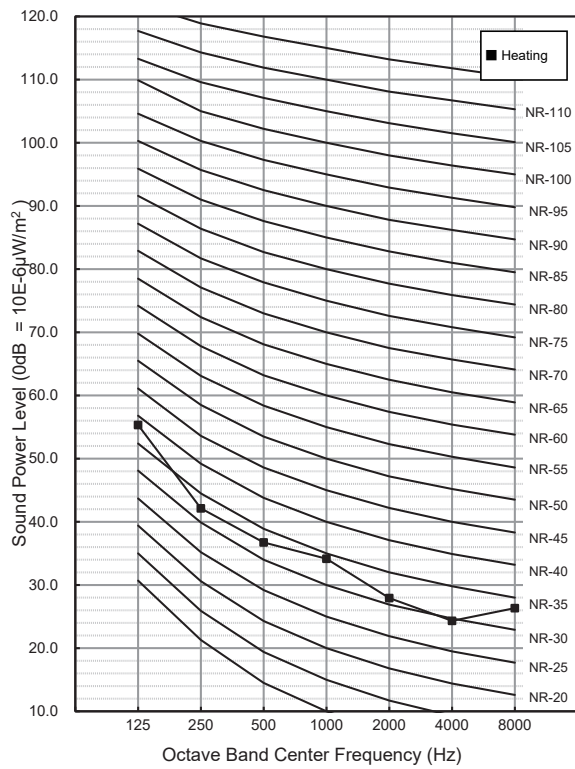

Sound level [dB(A), @ Standard condition]	
Heating(Rated)	44.0

Note

- Data is valid at diffuse field condition.
- Data is valid at nominal operating condition
- Sound level can be increased in static pressure mode or used air guide.
- Sound level will vary depending on a range of factors such as the construction (acoustic absorption coefficient) of particular room in which the equipment is installed.
- Reference acoustic intensity $OdB = 10E-6\mu W/m^2$
- Sound power level is measured on the rated condition in the semi-anechoic rooms by ISO 9614 standard. Therefore, these values can be increased owing to ambient conditions during operation.

1. ZHNW09606A1 [HN091MR NK5]

1.8 Hydraulic Performance

The water pump is variable type which is capable to change flow rate, so it may be required to change default water pump capacity in case of noise by water flow.

In most case, however, it is strongly recommended to set function of optimized flow control.

■ Pressure Drop

Capacity [kW]	Rated flow rate [LPM]	Pump Head [m] (at rated flow-rate)	Product pressure drop [m] (Plate Heat Exchanger)	Serviceable Head [m]	Min Flow-rate [LPM] (Recommend)
5	15.8	7.5	0.2	7.3	15
7	20.1	7.3	0.3	7.0	15
9	25.9	6.1	0.4	5.7	15

Q-H Chart

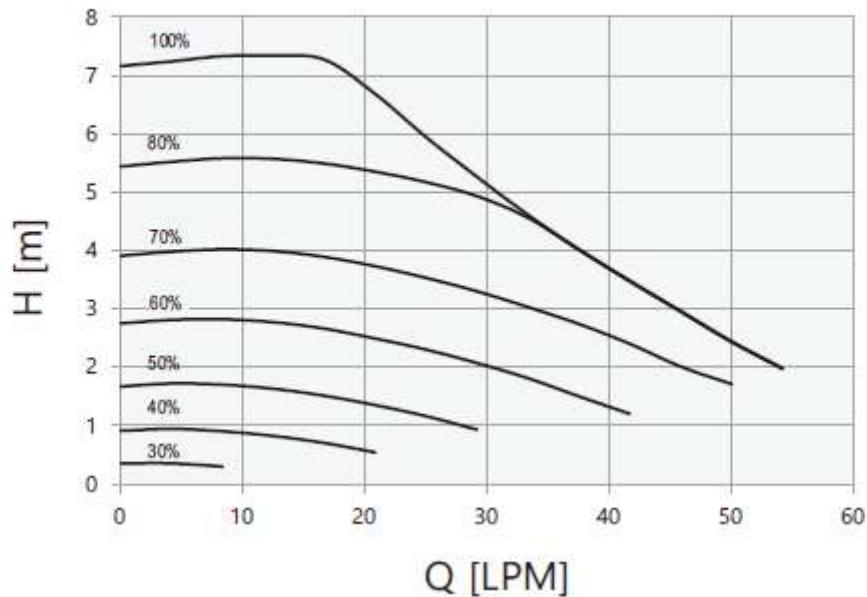

Note

- To secure enough water flow rate, do not set water pump capacity as Minimum. It can lead unexpected flow rate error CH14.
- When installing the product, install additional pump in consideration of the pressure loss and pump performance.
- If flow-rate is low, overloading of product can occur.
- Performance test based on standard ISO 9906 with pre-pressure 2.0 bar and liquid temperature 20°C.

1. ZHNW2060311 [HN0913T NK0]

1.1 Specifications

Category		Unit	Value
Major	Minor		
Classification	Chassis	-	K5
Current	Current(MAX)	A	0.6
Cooling Operation Range(Leaving Water)	For Fan Coil Unit(Min ~ Max)	°C	5 ~ 27
	For under floor(Min ~ Max)	°C	16 ~ 27
Heating Operation Range(Leaving Water)	Space Heating(Min ~ Max)	°C	15 ~ 65
	Domestic Hot Water(Min ~ Max)	°C	15 ~ 80
Water Pump	Type	-	Canned type for hot water circulation
	Model (Maker,Name)	-	GRUNDFOS(UPM3K 20-75 CHBL)
	Motor type	-	BLDC
	Steps of Pumping Performance	-	10~ 100%(19 Steps)
	Power input(Min~Max)	W	3 ~ 60
	Max. Head	m	7.5
Expansion Tank	Volume(Max)	ℓ	8
	Water Pressure(Max)	bar	3
	Water Pressure(Pre-charged)	bar	1
Strainer	Mesh size	mesh	30
	Max. particle size	mm	0.6
	Material	-	STS304
Safety Valve (Water cycle)	Pressure Limit(Upper Limit)	bar	3
Safety Valve (DHW)	Pressure Limit(Upper Limit)	bar	10
3 Way Valve	Model (Maker,Name)	-	Sanhua QSF-A02M20
	Motor Type	-	2-2 Step motor(DC 12V)
	Flow coefficient	Kvs	12
Flow Sensor	Type	-	Vortex
	Model (Maker,Name)	-	SIKA VVX20
	Measuring Range (Min~Max)	ℓ/min	5 ~ 80
Water Pressure Sensor	Model (Maker,Name)	-	Sensata OFM (2HMP)
	Measuring Range (Min~Max)	bar(G)	0 ~ 20
DHW Tank	Type	-	Internal coil type integrated hot water tank
	Water Volume	L	200
	Material	-	Duplex 2205
	Internal Thermal Protect limit	°C	85
	Pressure Limit (Max.)	MPa (bar)	0.1 (10)
DHW Tank Insulation	Material	-	Polyurethane foam
	Thickness	mm	50
Electric Backup Heater	Type	-	Sheath
	Power Supply	V, Φ, Hz	220-240, 1, 50
	Number of Heating Coil	EA	2
	Capacity Combination	kW	3
	Rated Current	A	13.0
	Maximum Electrical Power	kW	3
	Power Supply Cable(H07RN-F)	mm ² × cores	1.5 x 3C
Heat Exchanger (Water/DHW)	Type	-	Coil Heat Exchanger
	Quantity	EA	1
	Surface area	m ²	1.81
Heat Exchanger(Refrigerant to Water)	Type	-	Brazed Plate HEX(SWEP, QD20H)
	Quantity	EA	1
	Number of Plate	Sheet	52
Refrigerant Piping Connection	Liquid	mm(inch)	Φ9.52 (3/8)
	Gas	mm(inch)	Φ15.88 (5/8)

1. ZHNW20603I1 [HN0913T NK0]

Category		Unit	Value
Major	Minor		
Refrigerant Piping Connection	Connection Type(Liquid)	-	Flare
	Connection Type(Gas)	-	Flare
Water Connecting Pipes	Inlet	inch	FemaleG1" according to ISO228-1(parallel pipe threads)
	Outlet	inch	FemaleG1" according to ISO228-1(parallel pipe threads)
DHW Conneting Pipes	Inlet	inch	FemaleG1" according to ISO228-1(parallel pipe threads)
	Outlet	inch	FemaleG1" according to ISO228-1(parallel pipe threads)
	Re-circulation	inch	FemaleG1" according to ISO228-1(parallel pipe threads)
Sound Power Level	Heating(Rated)	dB(A)	42.0
Dimensions	Net(W x H x D)	mm	600 x 1,750 x 660
	Shipping(W x H x D)	mm	660 x 2,009 x 750
Weight	Net	kg	118.0
	Shipping	kg	140.0
Exterior	Color	-	Noble White
	RAL Code	-	RAL 9016
Connecting Cable	Power and Communication cable(H07RN-F)	mm ² × cores	0.75 x 4C

Note

- Due to our policy of innovation some specifications may be changed without notification.
- Wiring cable size must comply with the applicable local and national code. And “Electric characteristics” should be considered for electrical work and design. Especially the power cable and circuit breaker should be selected in accordance with that.
- Sound power level is measured on the rated condition in according with ISO 9614 standard. Therefore, these values depend on the ambient conditions and values are normally higher in actual operation.
- DHW 58~80°C operating is available only when the Electric heater is operating.

1. ZHNW20603I1 [HN0913T NK0]

1.2 List of Functions

Category	Functions	Value
Reliability	Self Diagnosis	O
Convenience	Auto Restart	O
	Child Lock	O
	Group Control	X
	Sleep Timer	O
	Turn On/Off Reservation	O
	Schedule	O
	Low Noise Operation	O
Installation	Electric Backup Heater	O
	Domestic Hot Water Tank heater	O (by Electric Backup Heater)
Water Product functions	Anti-Condensation On Floor (cooling)	O
	Water Pump ON / OFF Control	O
	Water Flow Detection	O (by Flow Sensor)
	Water Flow Control	O
	Water Pressure Monitoring	O
	Thermostat Interface (230V AC)	O
	Thermostat Interface (24V AC)	X
	Digital Output For External Pump	O
	Digital input for energy saving (LG ESS/ PV system)	O
	DHW(Domestic Hot Water) Tank Kit	O (Integrated)
	Solarthermal function	X
	PHEX Anti-Freezing Control	O
	Water Pump Forced Operation	O
	Anti-overheating Of Water Pipe	O
	Emergency Operation	O
	Weather Dependent Operation With Thermostat	O
	Weather Compensation For Heating And Cooling (Auto mode)	O
	Scheduler (DHW Tank Heater)	O
	Timer (DHW Tank Heater)	O
	Quick DHW Tank Heating	O
	Screed Drying Mode	O
One Point Dry Contact Input (CN-EXT)	O	
Energy Monitoring	O	
DHW Recirculation	O	
Special Functions	Wi-Fi Control	Accessory
	Modbus connectivity (without gateway)	O
	Remote room temperature sensing	O
	Outdoor Temperature sensing	O
	2nd Circuit / Mixer control	O
	2-Remo control	O

Note

■ O : Applied, X : Not Applied

- Accessory : Ordered and purchased separately the accessory package referring to the model name provided and install at field.

- Accessory line-ups varies by region, so check your local catalogue or local sales material.

1. ZHNW2060311 [HN0913T NK0]

1.3 Accessory Compatibility List

Category	Accessory Name	Model Name	Description	Value
Remote Controller	Wired - RS3 (Standard III)	PREMTW101	White	O
Dry Contact	Simple	PDRYCB000	1 input port, AC 220 - 240V	O
	Communication	PDRYCB320	8 input port, For 3rd Party Thermostat (Analog Input)	O
Integration Device	Remote Temperature sensor	PQRSTA0	-	O
	Group Control wire	PZCWRCG3	Cable Assembly for group control (Y-type cable : 0.25m, cable : 9.6m)	X
ETC	Extension wire	PZCWRC1	Extension wire for IDU-wired remote controller (9.6m)	O
	2-Remo Control wire	PZCWRC2	-	O
	Wi-Fi Modem	PWFMD200	-	O
	Wi-Fi Extension cable	PWYREW000	USB Extension cable : 10 m	O
	Meter Interface	PENKTH000	-	O
Special Kit	Solar-Thermal Interface kit with DHW Tank	PHLLA	Limit Temperature : 96 °C	X
	Indoor Drain Pan	PHDPB	For Split Hydro Box	X
		PHDPC	For Split Hydro Box	X
	DHW tanks (Single coil)	OSHW-200F	200 L	X
		OSHW-300F	300 L	X
		OSHW-500F	500 L	X
	DHW tanks (Double coil)	OSHW-300FD	300 L	X
	DHW tank kit	PHLTA	For Split Hydro Box(except for HN1639 NK3)	X
		PHLTC	For Split Hydro Box(HN1639 NK3)	X
	DHW sensor	PHRSTA0	-	X
	Thermostatic Mixing valve	OSHA-MV	3/4" DN20	O
		OSHA-MV1	1" DN25	O
	3way valve	OSHA-3V	-	X
	2nd Circuit Thermistor	PRSTAT5K10	-	O
	Backup Heater	HA061B E1	1Ø, 6kW (For Hydrosplit, HN1600MB NK0)	X
		HA061C E1	1Ø, 6kW (For Hydrosplit, HN1600MC NK1)	X
HA063B E1		3Ø, 6kW (For Hydrosplit, HN1600MB NK0)	X	
HA063C E1		3Ø, 6kW (For Hydrosplit, HN1600MC NK1)	X	
Cover plate	PDC-HK10	For IWT and Hydro Box Type indoor units	O	

Note

- O: Possible, X: Impossible, -: Unconfirmed or irrelevant, Embedded : Included with product.
- Some advanced functions controlled by individual controller cannot be operated.
- If there is a difference in development time between the product and the remote controller, some functions cannot be operated.
- Meter Interface cannot be connected at the same time with 3rd-party controller.
- If you need more detail, please refer to the Control(BECON) PDB or the manual of product.
(<http://partner.lge.com/global> : Home> Doc.Library> Product > Control(BECON)).

1. ZHNW20603I1 [HN0913T NK0]

1.4 Dimensions

1.4.1 Internal

[Unit:mm]

Chassis code: K5

P/No. : TBJ37803001_rev.01

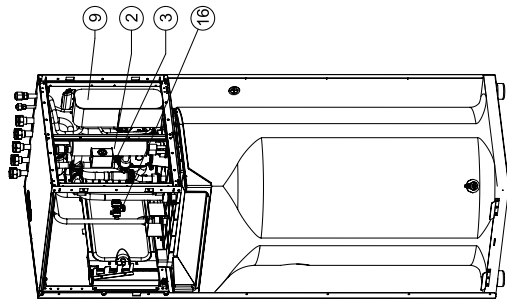
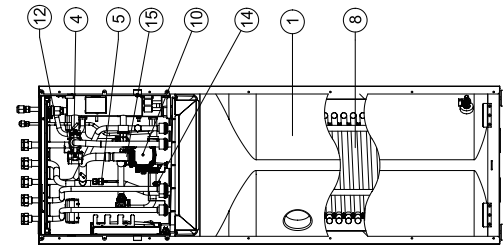
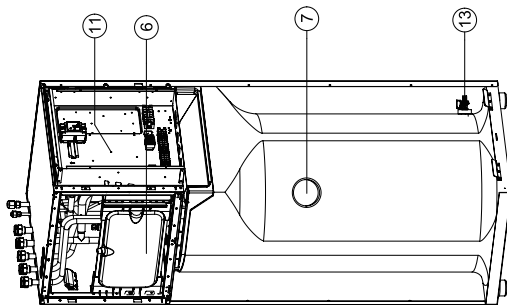
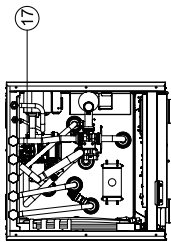

17	Safety valve	For water circuit (3 bar)
16	Safety valve	For DHW (10 bar)
15	Strainer	For water circuit
14	Drain cock 2	Valve for water circuit drain
13	Drain cock 1	Valve for DHW Tank drain
12	Air vent	For Air purging
11	Control Box	PCBA and Terminal blocks
10	Water pump	Main circulation pump
9	Heat exchanger 2	Plate Heat Exchange (Ref. / Water)
8	Heat exchanger 1	Coil Heat Exchange (water / DHW)
7	DHW tank sensor	Temperature sensor
6	Expansion vessel	8L for Heating circuit
5	Pressure sensor	Pressure sensor
4	3Way valve	For DHW / Heating
3	Flow sensor	Flow metering sensor
2	Heater	Electric heater (3kW)
1	DHW Tank	Domestic hot water tank(200L)
No.	Part Name	Description

1. ZHNW20603I1 [HN0913T NK0]

1.4.2 External

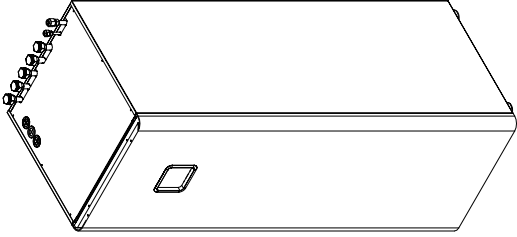
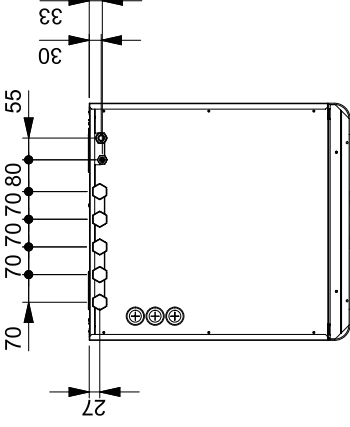
[Unit:mm]

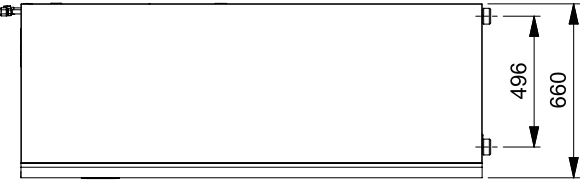
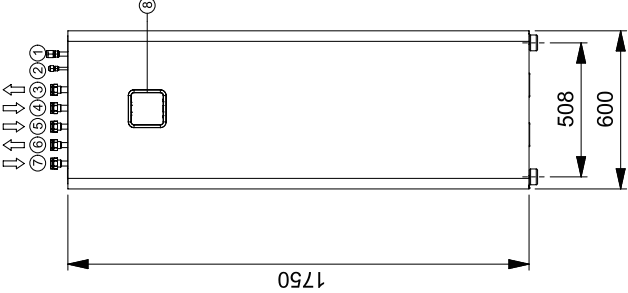
Chassis code: K5

P/No. : TBJ37803001_rev.01

8	Control panel	Built-in Remote controller
7	DHW RE-Circulation pipe	
6	Domestic hot water outlet pipe	
5	Domestic cold water inlet pipe	Female G1" according to ISO228-1 (parallel pipe threads)
4	Heating circuit inlet pipe	
3	Heating circuit outlet pipe	
2	Refrigerant liquid pipe	SAE 3/8"
1	Refrigerant gas pipe	SAE 5/8"
No.	Part Name	Description

1. ZHNW20603I1 [HN0913T NK0]

1.5 Piping Diagrams

1.5.1 Normal

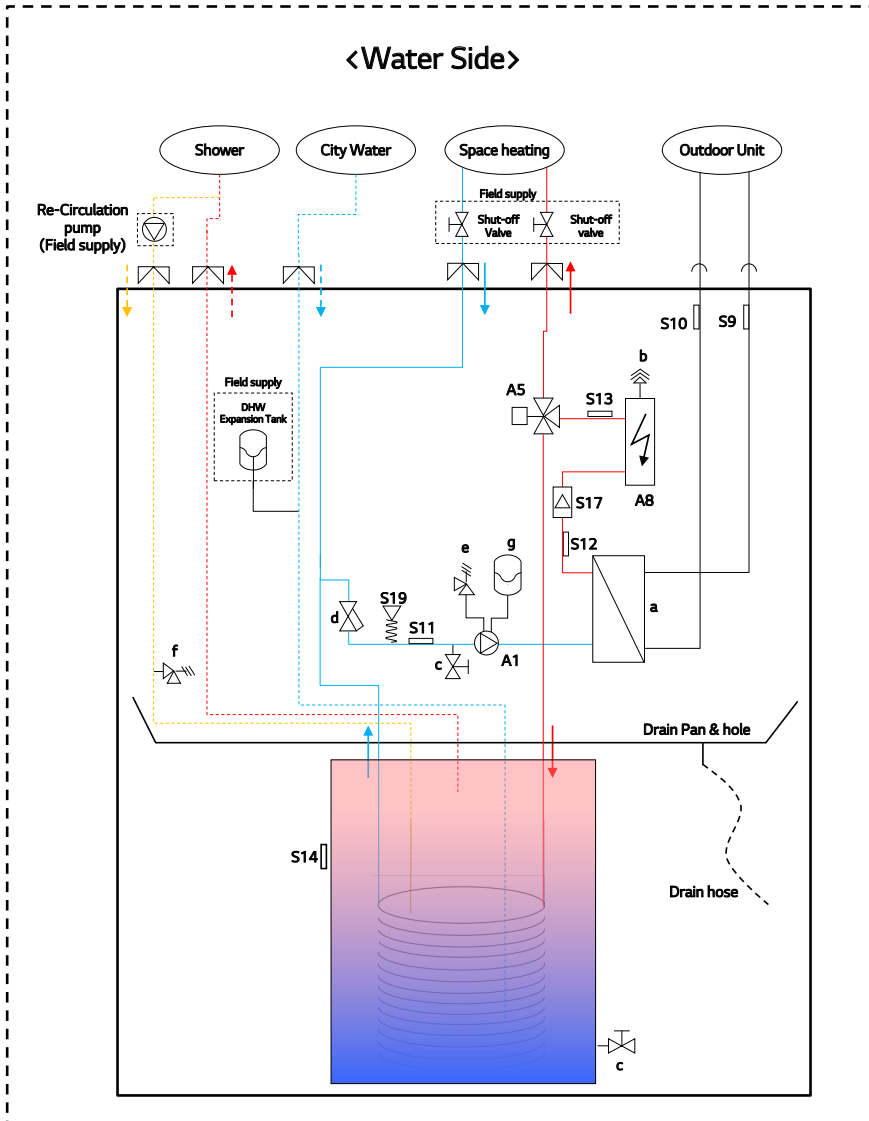

Category	Symbol	Meaning
Refrigerant side	S9	PHEX gas temp.sensor
	S10	PHEX liquid temp.sensor
Water Side	S11	Inlet water temperature sensor
	S12	Outlet water temperature sensor
	S13	Electric heater outlet sensor
	S14	DHW tank temperature sensor
	S17	Flow sensor
	S19	Water pressure sensor
	A1	Main water pump
	A5	3Way Valve
	A8	Electric backup heater
	a	PHEX (Ref. / Water)
	b	Air vent
	c	Drain valve
	d	Strainer
e	Safety valve(water circuit, 3bar)	
f	Safety valve(DHW tank, 10bar)	
g	Expansion Tank(8L)	

1. ZHNW2060311 [HN0913T NK0]

1.6 Wiring Diagrams

CIRCUIT DIAGRAM : INDOOR UNIT

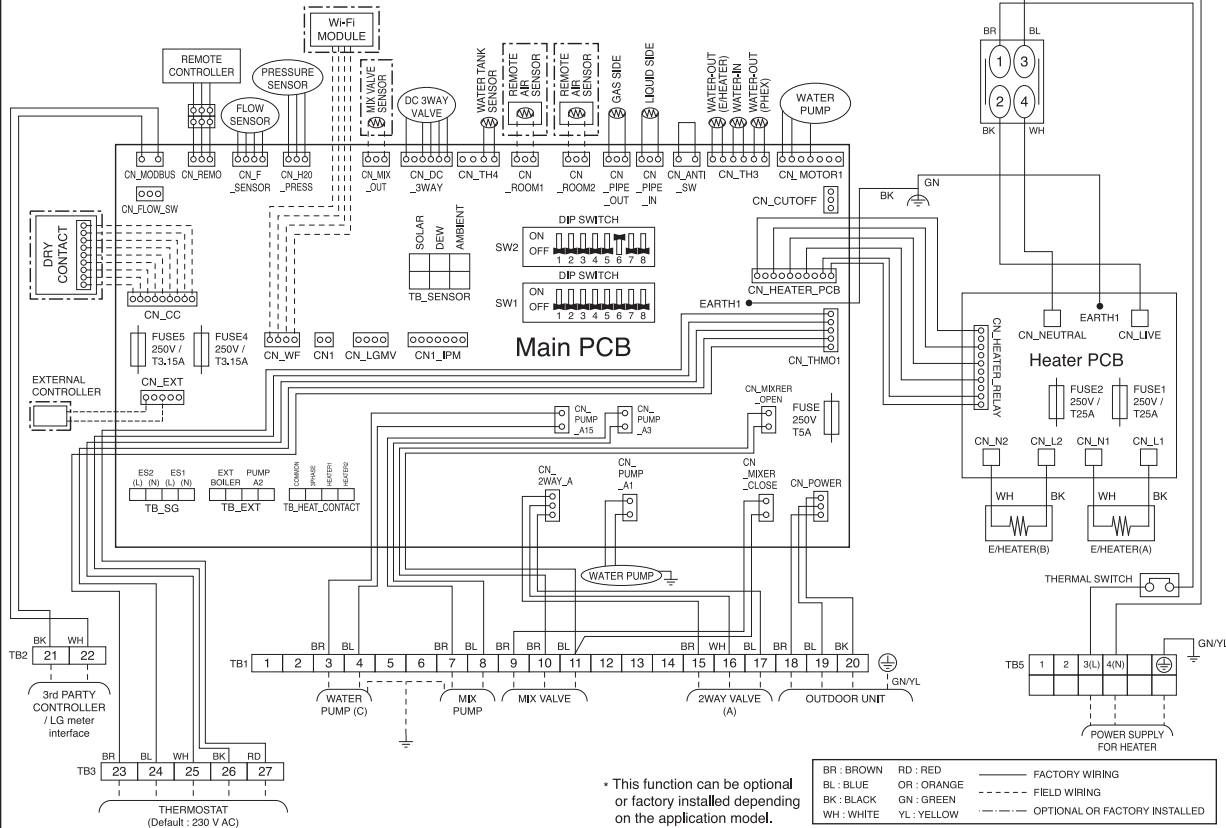

EXTERNAL CIRCUIT DIAGRAM : INDOOR UNIT

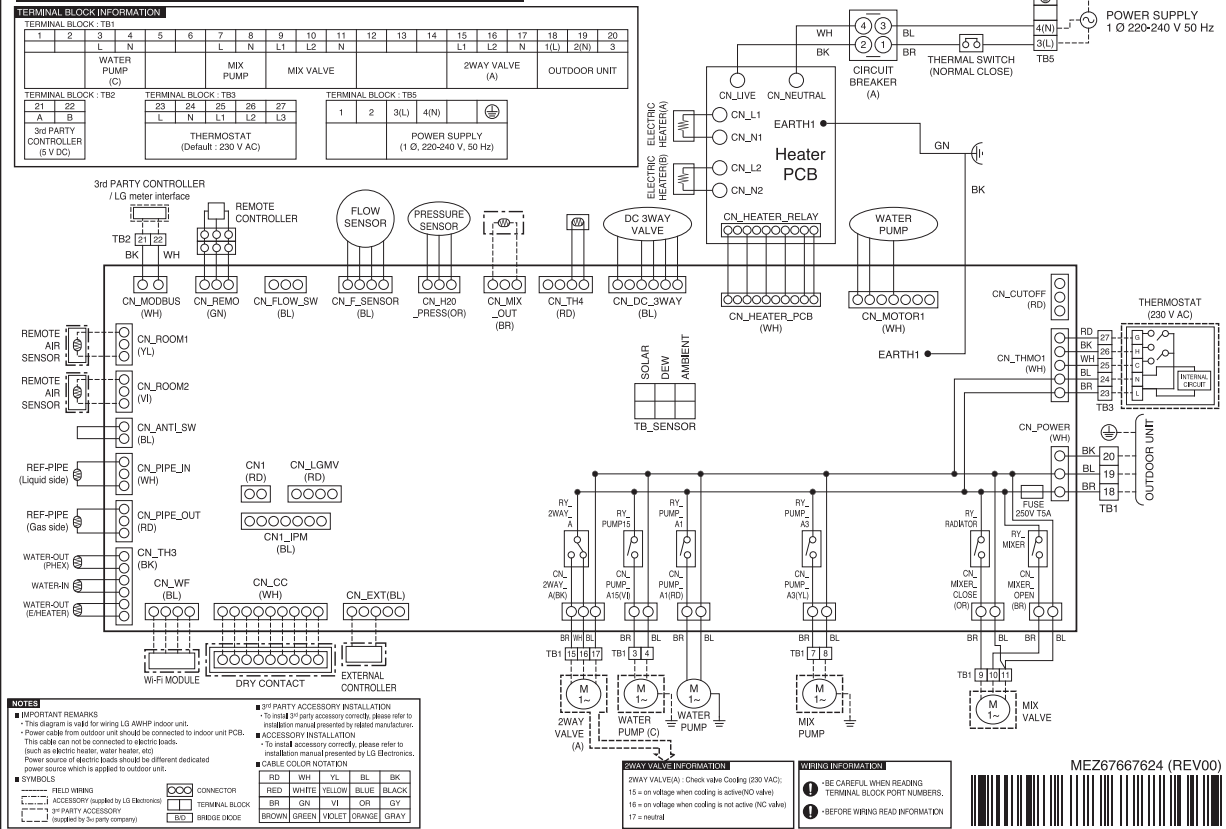

1. ZHNW20603I1 [HN0913T NK0]

1.7 Sound Levels

1.7.1 Power Levels

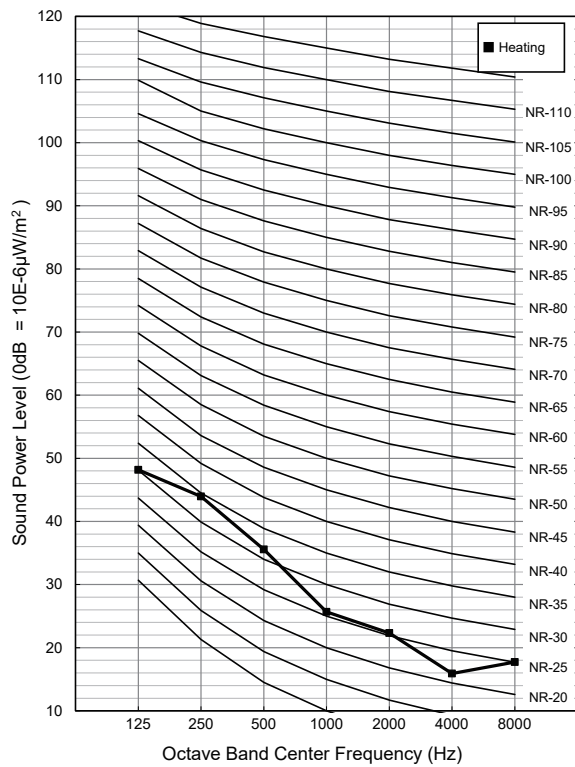

Sound level [dB(A), @ Standard condition]	
Heating(Rated)	42.0

Note

- Data is valid at diffuse field condition.
- Data is valid at nominal operating condition
- Sound level can be increased in static pressure mode or used air guide.
- Sound level will vary depending on a range of factors such as the construction (acoustic absorption coefficient) of particular room in which the equipment is installed.
- Reference acoustic intensity 0dB = 10E-6μW/m2
- Sound power level is measured on the rated condition in the semi-anechoic rooms by ISO 9614 standard. Therefore, these values can be increased owing to ambient conditions during operation.

1. ZHNW20603I1 [HN0913T NK0]

1.8 Hydraulic Performance

The water pump is variable type which is capable to change flow rate, so it may be required to change default water pump capacity in case of noise by water flow.

In most case, however, it is strongly recommended to set function of optimized flow control.

■ Pressure Drop

Capacity [kW]	Rated flow rate [LPM]	Pump Head [m] (at rated flow-rate)	Product pressure drop [m] (Plate Heat Exchanger)	Serviceable Head [m]	Min Flow-rate [LPM] (Recommend)
5	15.8	7.5	0.2	7.3	15
7	20.1	7.3	0.3	7.0	15
9	25.9	6.1	0.4	5.7	15

Q-H Chart

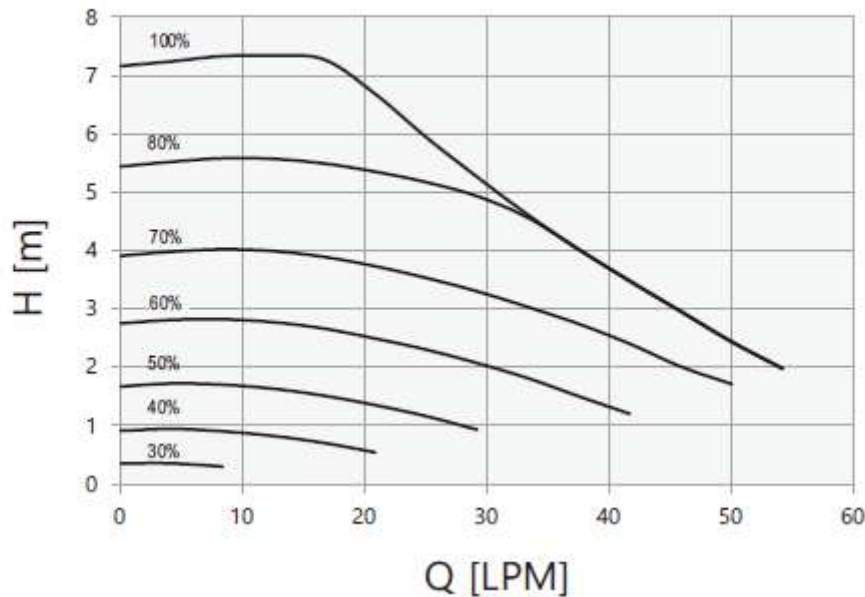

Note

- To secure enough water flow rate, do not set water pump capacity as Minimum. It can lead unexpected flow rate error CH14.
- When installing the product, install additional pump in consideration of the pressure loss and pump performance.
- If flow-rate is low, overloading of product can occur.
- Performance test based on standard ISO 9906 with pre-pressure 2.0 bar and liquid temperature 20°C.

THERMA VTM

Split Type

Outdoor unit

- 1. Specification**
- 2. List of functions**
- 3. Accessory Compatibility List**
- 4. Dimensions**
- 5. Piping Diagram**
- 6. Capacity Tables**
- 7. Wiring Diagram**
- 8. Operation Limits**
- 9. Sound Levels**

1. Specifications

1.1 Nominal Capacity and Power Input

■ Combination with Hydro Box type

Outdoor Name		Unit	ZHUW056A0 [HU051MR]	ZHUW076A0 [HU071MR]	ZHUW096A0 [HU091MR]
Combination Indoor Name			ZHNW09606A1 [HN091MR]	ZHNW09606A1 [HN091MR]	ZHNW09606A1 [HN091MR]
Classification	Chassis	-	U36A	U36A	U36A
Power Supply	-	V, Φ , Hz	220-230-240, 1, 50	220-230-240, 1, 50	220-230-240, 1, 50
	Limit Range of Voltage	V	187 ~ 276	187 ~ 276	187 ~ 276
Heater Power Supply	-	V, Φ , Hz	220-230-240, 1, 50	220-230-240, 1, 50	220-230-240, 1, 50
Heater Power Input	-	W	6,000	6,000	6,000
Capacity(Heating)	A7 / W35	kW	5.50	7.00	9.00
	A7 / W55	kW	5.50	5.50	5.50
	A2 / W35	kW	3.30	4.20	5.40
Capacity(Cooling)	A35 / W18	kW	5.50	7.00	9.00
	A35 / W7	kW	5.50	7.00	9.00
	A7 / W35	kW	1.12	1.43	1.94
Power Input(Heating)	A7 / W55	kW	2.04	2.04	2.04
	A2 / W35	kW	0.94	1.20	1.54
	A35 / W18	kW	1.20	1.56	2.14
Power Input(Cooling)	A35 / W7	kW	1.96	2.59	3.46
	A7 / W35	W/W	4.90	4.90	4.65
	A7 / W55	W/W	2.70	2.70	2.70
COP(Heating)	A2 / W35	W/W	3.52	3.51	3.50
	A35 / W18	W/W	4.60	4.50	4.20
EER(Cooling)	A35 / W7	W/W	2.80	2.70	2.60
	Water outlet 35°C	W/W	4.65	4.65	4.65
SCOP (Average climate)	Water outlet 55°C	W/W	3.23	3.23	3.23
	profile L	%	-	-	-
Water Heating Efficiency (Average climate)	profile XL	%	-	-	-
	Rated(at ΔT 5°C)	l/min	15.81	20.12	25.87
Sound Power Level	Heating(Low Noise)	dB(A)	58.0	58.0	58.0
	Heating(Rated)	dB(A)	60.0	60.0	60.0
Running Current	Heating(Rated)	A	5.0	6.3	8.6
	Cooling(Rated)	A	5.3	6.9	9.5
Peak Contorl Running Current	Heating	A	13.0	14.0	15.0
	Cooling	A	13.0	14.0	15.0
Circuit Breaker	-	A	20.0	25.0	30.0

Note

- Due to our policy of innovation some specifications may be changed without notification.
- Wiring cable size must comply with the applicable local and national codes. And "Electric characteristics" chapter should be considered for electrical work and design. Especially the power cable and circuit breaker should be selected in accordance with that.
- Sound power level is measured on the rated condition in accordance with ISO 9614 standard.
Therefore, these values can be increased owing to ambient conditions during operation.
- Performances are accordance with EN14511 and reflect ErP testing conditions. Above gives the declared values at rated conditions acc. ErP regulation
 - Cooling
 - A35 / W18 : Outdoor Temp. 35°C(DB) / 24°C(WB), Leaving Water Temp. 18°C
 - A35 / W7 : Outdoor Temp. 35°C(DB) / 24°C(WB), Leaving Water Temp. 7°C
 - Heating
 - A7 / W35 : Outdoor Temp. 7°C(DB) / 6°C(WB), Leaving Water Temp. 35°C
 - A7 / W55 : Outdoor Temp. 7°C(DB) / 6°C(WB), Leaving Water Temp. 55°C
 - A2 / W35 : Outdoor Temp. 2°C(DB) / 1°C(WB), Leaving Water Temp. 35°C
 - Interconnected Pipe Length is standard length and difference of Elevation (Outdoor ~ Indoor Unit) is 0m.
- This product contains Fluorinated greenhouse gases.
- SCOP is accordance with EN14825.
- Water Heating Efficiency is accordance with EN16147.
- All installation site must require attachment of an earth leakage breaker. [circuit breaker type is ELCB(Earth Leakage Circuit Breaker)].

1. Specifications

■ Combination with IWT

Outdoor Name		Unit	ZHUW056A0 [HU051MR]	ZHUW076A0 [HU071MR]	ZHUW096A0 [HU091MR]
Combination Indoor Name			ZHNW206031 [HN0913T]	ZHNW206031 [HN0913T]	ZHNW206031 [HN0913T]
Classification	Chassis	-	U36A	U36A	U36A
Power Supply	-	-	220-230-240, 1, 50	220-230-240, 1, 50	220-230-240, 1, 50
	Limit Range of Voltage	V	187 ~ 276	187 ~ 276	187 ~ 276
Heater Power Supply	-	V, Φ , Hz	220-230-240, 1, 50	220-230-240, 1, 50	220-230-240, 1, 50
Heater Power Input	-	W	3,000	3,000	3,000
Capacity(Heating)	A7 / W35	kW	5.50	7.00	9.00
	A7 / W55	kW	5.50	5.50	5.50
	A2 / W35	kW	3.30	4.20	5.40
Capacity(Cooling)	A35 / W18	kW	5.50	7.00	9.00
	A35 / W7	kW	5.50	7.00	9.00
	A7 / W35	kW	1.12	1.43	1.94
Power Input(Heating)	A7 / W55	kW	2.04	2.04	2.04
	A2 / W35	kW	0.94	1.20	1.54
	A35 / W18	kW	1.20	1.56	2.14
Power Input(Cooling)	A35 / W7	kW	1.96	2.59	3.46
	A7 / W35	W/W	4.90	4.90	4.65
COP(Heating)	A7 / W55	W/W	2.70	2.70	2.70
	A2 / W35	W/W	3.52	3.51	3.50
	A35 / W18	W/W	4.60	4.50	4.20
EER(Cooling)	A35 / W7	W/W	2.80	2.70	2.60
	Water outlet 35°C	W/W	4.65	4.65	4.65
SCOP (Average climate)	Water outlet 55°C	W/W	3.23	3.23	3.23
	profile L	%	133	133	-
Water Heating Efficiency (Average climate)	profile XL	%	-	-	140
	Rated(at ΔT 5°C)	l/min	15.81	20.12	25.87
Sound Power Level	Heating(Low Noise)	dB(A)	58.0	58.0	58.0
	Heating(Rated)	dB(A)	60.0	60.0	60.0
Running Current	Heating(Rated)	A	5.0	6.3	8.6
	Cooling(Rated)	A	5.3	6.9	9.5
Peak Contorl Running Current	Heating	A	13.0	14.0	15.0
	Cooling	A	13.0	14.0	15.0
Circuit Breaker	-	A	20.0	25.0	30.0

Note

- Due to our policy of innovation some specifications may be changed without notification.
- Wiring cable size must comply with the applicable local and national codes. And "Electric characteristics" chapter should be considered for electrical work and design. Especially the power cable and circuit breaker should be selected in accordance with that.
- Sound power level is measured on the rated condition in accordance with ISO 9614 standard.
Therefore, these values can be increased owing to ambient conditions during operation.
- Performances are accordance with EN14511 and reflect ErP testing conditions. Above gives the declared values at rated conditions acc. ErP regulation
 - Cooling
 - A35 / W18 : Outdoor Temp. 35°C(DB) / 24°C(WB), Leaving Water Temp. 18°C
 - A35 / W7 : Outdoor Temp. 35°C(DB) / 24°C(WB), Leaving Water Temp. 7°C
 - Heating
 - A7 / W35 : Outdoor Temp. 7°C(DB) / 6°C(WB), Leaving Water Temp. 35°C
 - A7 / W55 : Outdoor Temp. 7°C(DB) / 6°C(WB), Leaving Water Temp. 55°C
 - A2 / W35 : Outdoor Temp. 2°C(DB) / 1°C(WB), Leaving Water Temp. 35°C
 - Interconnected Pipe Length is standard length and difference of Elevation (Outdoor ~ Indoor Unit) is 0m.
- This product contains Fluorinated greenhouse gases.
- SCOP is accordance with EN14825.
- Water Heating Efficiency is accordance with EN16147.
- All installation site must require attachment of an earth leakage breaker. [circuit breaker type is ELCB(Earth Leakage Circuit Breaker)].

1. Specifications

1.2 Outdoor unit

Model Name		Unit	ZHUW056A0 [HU051MR]	ZHUW076A0 [HU071MR]	ZHUW096A0 [HU091MR]
Classification	Chassis	-	U36A	U36A	U36A
Power Supply	-	V, Φ , Hz	220-230-240, 1, 50	220-230-240, 1, 50	220-230-240, 1, 50
	Limit Range of Voltage	V	187 ~ 276	187 ~ 276	187 ~ 276
Operation Range(Outdoor Temperature)	Cooling(Min ~ Max)	$^{\circ}\text{C}(\text{DB})$	5 ~ 48	5 ~ 48	5 ~ 48
	Heating(Min ~ Max)	$^{\circ}\text{C}(\text{DB})$	-25 ~ 35	-25 ~ 35	-25 ~ 35
Fan	Type	-	Propeller	Propeller	Propeller
	Air Flow Rate(Rated)	$\text{m}^3/\text{min} \times \text{No.}$	60 x 1	60 x 1	60 x 1
Fan Motor	Type	-	BLDC	BLDC	BLDC
	Output	W x No.	124 x 1	124 x 1	124 x 1
Compressor	Type	-	Hermetic Sealed Scroll	Hermetic Sealed Scroll	Hermetic Sealed Scroll
	Model x No.	-	RJB036MAA x 1	RJB036MAA x 1	RJB036MAA x 1
	Piston Displacement	cm^3/rev	31.6	31.6	31.6
	Motor Type	-	BLDC	BLDC	BLDC
Refrigerant	Type	-	R32	R32	R32
	Precharged Amount	kg	1.5	1.5	1.5
	Additional Charging amount	g/m	40	40	40
	GWP(Global Warming Potential)	-	675	675	675
	t-CO ₂ eq.	-	1.013	1.013	1.013
	Chargeless-Pipe Length	m	10	10	10
	Control Type	-	EEV	EEV	EEV
Refrigerant Oil	Type	-	FW68D	FW68D	FW68D
	Charged Volume	cc x No.	1,100 x 1	1,100 x 1	1,100 x 1
Heat Exchanger	Rows x Columns x FPI	-	2 x 38 x 14	2 x 38 x 14	2 x 38 x 14
	No.	-	1	1	1
	Fin Type	-	Fin & Tube	Fin & Tube	Fin & Tube
Refrigerant Piping Connection	Liquid	mm(inch)	$\Phi 9.52$ (3/8)	$\Phi 9.52$ (3/8)	$\Phi 9.52$ (3/8)
	Gas	mm(inch)	$\Phi 15.88$ (5/8)	$\Phi 15.88$ (5/8)	$\Phi 15.88$ (5/8)
	Connection Type(Liquid)	-	Flare	Flare	Flare
	Connection Type(Gas)	-	Flare	Flare	Flare
Dimensions	Net(W x H x D)	mm	950 x 834 x 330	950 x 834 x 330	950 x 834 x 330
	Shipping(W x H x D)	mm	1,147 x 919 x 461	1,147 x 919 x 461	1,147 x 919 x 461
Weight	Net	kg	60.0	60.0	60.0
	Shipping	kg	65.0	65.0	65.0
Exterior	Color	-	Warm Gray	Warm Gray	Warm Gray
	RAL Code	-	RAL 7044	RAL 7044	RAL 7044
Piping Length	Rated / Max	m	50	50	50
Maximum Height Difference	IDU - ODU(Max)	m	30	30	30
Connecting Cable	Power Supply Cable(H07RN-F)	$\text{mm}^2 \times \text{cores}$	4.0 x 3C	4.0 x 3C	4.0 x 3C

Note

1. Due to our policy of innovation some specifications may be changed without notification.
2. Wiring cable size must comply with the applicable local and national codes. And "Electric characteristics" chapter should be considered for electrical work and design. Especially the power cable and circuit breaker should be selected in accordance with that.

2. List of functions

Category	Functions	ZHUW056A0 [HU051MR U44] ZHUW076A0 [HU071MR U44] ZHUW096A0 [HU091MR U44]
Reliability	Defrost / Deicing	O
	High Pressure Switch	O
	Low Pressure Switch	X
	Phase Protection	X
	Restart Delay (3-minutes)	O
	Self Diagnosis	O
	Soft Start	X
	Sump Heater	X
Convenience	Base Pan Heater	O
	Test Function	X
	Low Noise Operation	O
	Wiring Error Check	X
	Peak Control	O
	Mode Lock	O
	Forced Cooling Operation (Outdoor Unit)	X
SLC(Smart Load Control)	X	

Note

1. O : Applied, X : Not applied

Accessory : Ordered and purchased separately the accessory package referring to the model name provided and install at field.
Accessory line-ups varies by region, so check your local catalogue or local sales material.

3. Accessory Compatibility List

Category		Product	Remark	ZHUW056A0 [HU051MR U44] ZHUW076A0 [HU071MR U44] ZHUW096A0 [HU091MR U44]
Central Controller	AC EZ	PQCSZ250S0	Small type	X
	AC EZ touch	PACEZA000	Small / Touch type	O
	AC Smart IV	PACS4B000	Touch type	O
	AC Smart 5	PACS5A000	Touch type	O
	ACP IV	PACP4B000	-	O
	ACP 5	PACP5A000	-	O
	AC Manager IV	PACM4B000	Integrated	O
	AC Manager 5	PACM5A000	Integrated	O
Gateway	ODU PI485	PMNFP14A1	For 16-room (3 series)	X (from 09/2021)
	ODU PI485	PP485A00T	-	O
	ACP BACnet	PQNFB17C0	-	O
	ACP Lonwork	PLNWKB000	-	O
	Cloud Gateway	PWFMDB200	-	O
	Modbus RTU Gateway	PMBUSB00A	To interwork with 3rd Party Controller or BMS for Multi V 5 / ERV (DX) / AWHP / Hydrokit	O
Integration Device	PDI Stadnard	PPWRDB000	Power distributor 2port	O
	PDI Premium	PQNUD1S40	Power distributor 8port	O

Note

1. O: Possible, X: Impossible, - : Unconfirmed or irrelevant, Embedded : Included with product.
2. Some advanced functions controlled by individual controller cannot be operated.
3. AC Manager requires ACP or AC Smart.
4. If you need more detail, please refer to the Control(BECON) PDB or the manual of product.(<http://partner.lge.com/global> : Home> Doc.Library> Product > Control(BECON) PDB).

5. Piping Diagram

◆ ZHUW056A0 [HU051MR U44], ZHUW076A0 [HU071MR U44], ZHUW096A0 [HU091MR U44]

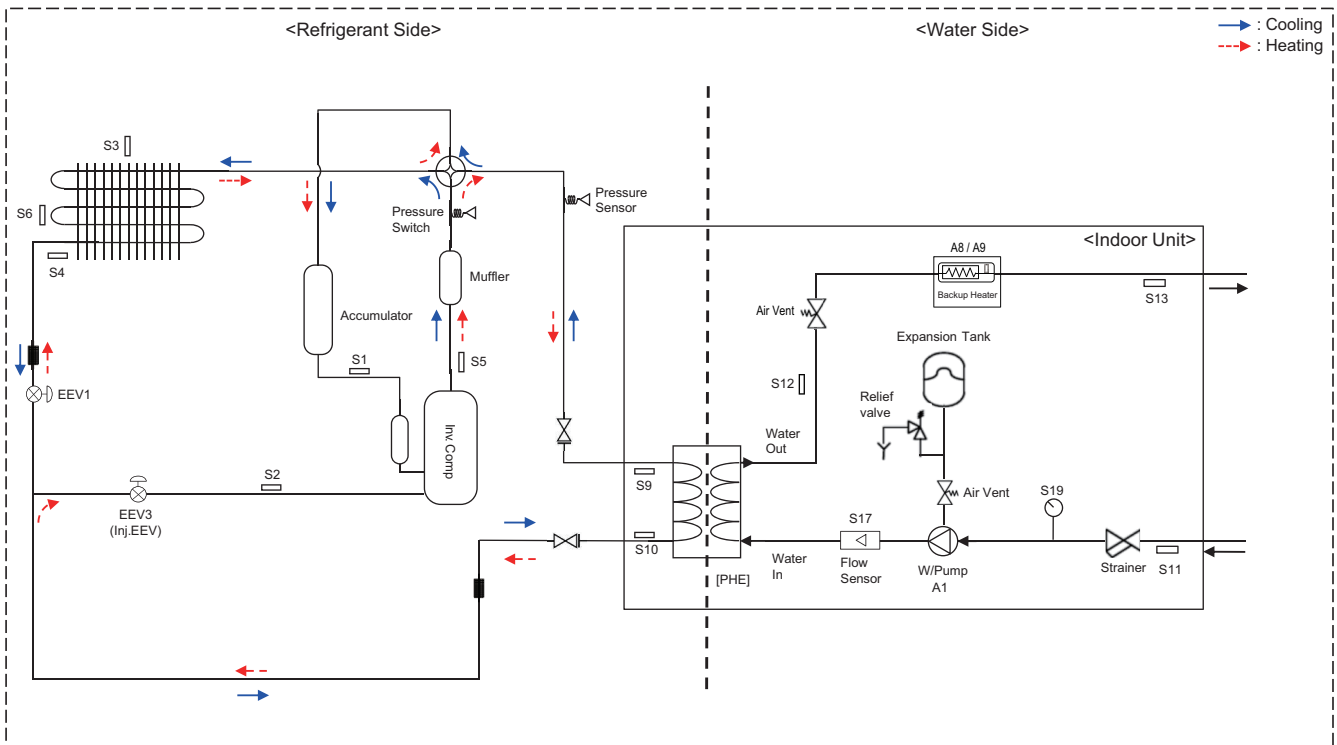

* This is a piping diagram when combined with hydro box kit. Refer to the indoor unit for the piping diagram of the IWT.

Category	Symbol	Meaning
Refrigerant side	S1	Compressor-suction pipe temperature sensor
	S2	Injection EEV discharge temperature sensor
	S3	Outdoor air temperature sensor
	S4	Outdoor-HEX temperature sensor
	S5	Compressor-discharge pipe temperature sensor
	S6	Outdoor-HEX middle temperature sensor
	S9	PHEX gas temperature sensor
	S10	PHEX liquid temperature sensor
	EEV1	Electronic Expansion Valve
	EEV3	EEV3 Electronic Expansion Valve (Injection)
Water Side	S11	Inlet water temperature sensor (WATER IN)
	S12	Outlet water temperature sensor (PHEX OUT)
	S13	Backup heater outlet sensor (WATER OUT)
	S17	Flow sensor
	S19	Pressure sensor
	A1	Main water pump
	A8	Electric backup heater (Step1)
A9	Electric backup heater (Step 2)	

6. Capacity Tables

6.1 Cooling Operation

6.1.1 Combination with Hydro Box type

■ Maximum Cooling Capacity

◆ ZHUW056A0 [HU051MR U44] + ZHNW09606A1 [HN091MR NK5]

Outdoor Temperature [°C DB]	Water flow rate 15.8 LPM													
	LWT 7 °C		LWT 10 °C		LWT 13 °C		LWT 15 °C		LWT 18 °C		LWT 20 °C		LWT 22 °C	
	TC	EER	TC	EER	TC	EER	TC	EER	TC	EER	TC	EER	TC	EER
10	6.42	4.57	6.95	4.85	7.49	5.13	7.85	5.31	8.39	5.59	8.75	5.78	9.11	5.96
20	6.05	3.86	6.37	4.23	6.70	4.61	6.91	4.86	7.23	5.23	7.45	5.48	7.66	5.74
30	5.68	3.15	5.79	3.62	5.90	4.09	5.97	4.41	6.08	4.88	6.15	5.19	6.22	5.51
35	5.50	2.80	5.50	3.32	5.50	3.84	5.50	4.18	5.50	4.60	5.50	5.05	5.50	5.39
40	5.32	2.45	5.34	2.84	5.35	3.24	5.37	3.50	5.38	3.90	5.40	4.17	5.41	4.43
45	5.13	2.09	5.17	2.37	5.21	2.64	5.23	2.83	5.27	3.10	5.29	3.29	5.32	3.47

◆ ZHUW076A0 [HU071MR U44] + ZHNW09606A1 [HN091MR NK5]

Outdoor Temperature [°C DB]	Water flow rate 20.1 LPM													
	LWT 7 °C		LWT 10 °C		LWT 13 °C		LWT 15 °C		LWT 18 °C		LWT 20 °C		LWT 22 °C	
	TC	EER	TC	EER	TC	EER	TC	EER	TC	EER	TC	EER	TC	EER
10	8.17	4.37	8.85	4.64	9.54	4.91	9.99	5.09	10.68	5.35	11.13	5.53	11.59	5.71
20	7.70	3.70	8.11	4.06	8.52	4.42	8.80	4.66	9.21	5.01	9.48	5.25	9.75	5.49
30	7.23	3.03	7.37	3.48	7.51	3.93	7.60	4.22	7.74	4.67	7.83	4.97	7.92	5.27
35	7.00	2.70	7.00	3.19	7.00	3.68	7.00	4.01	7.00	4.50	7.00	4.83	7.00	5.15
40	6.77	2.37	6.79	2.74	6.81	3.11	6.83	3.36	6.85	3.74	6.87	3.99	6.88	4.24
45	6.53	2.03	6.58	2.29	6.63	2.55	6.66	2.72	6.70	2.98	6.74	3.15	6.77	3.32

◆ ZHUW096A0 [HU091MR U44] + ZHNW09606A1 [HN091MR NK5]

Outdoor Temperature [°C DB]	Water flow rate 25.9 LPM													
	LWT 7 °C		LWT 10 °C		LWT 13 °C		LWT 15 °C		LWT 18 °C		LWT 20 °C		LWT 22 °C	
	TC	EER	TC	EER	TC	EER	TC	EER	TC	EER	TC	EER	TC	EER
10	10.50	4.08	11.38	4.33	12.26	4.58	12.85	4.75	13.73	5.00	14.31	5.16	14.90	5.33
20	9.90	3.49	10.43	3.81	10.96	4.14	11.31	4.35	11.84	4.68	12.19	4.89	12.54	5.11
30	9.30	2.90	9.48	3.30	9.65	3.69	9.77	3.96	9.95	4.36	10.06	4.63	10.18	4.89
35	9.00	2.60	9.00	3.04	9.00	3.47	9.00	3.76	9.00	4.20	9.00	4.49	9.00	4.78
40	8.70	2.30	8.73	2.63	8.76	2.96	8.78	3.18	8.81	3.50	8.83	3.72	8.85	3.94
45	8.40	2.01	8.46	2.23	8.52	2.44	8.56	2.59	8.62	2.81	8.66	2.95	8.70	3.10

Note

1. DB : Dry bulb temperature(°C), LWT : Leaving water temperature(°C), LPM : Liter per minute (ℓ/min)
2. TC : Total capacity(kW), EER: Energy efficiency ratio(kW/kW), COP : Coefficient of performance (kW/kW)
3. Direct interpolation is permissible. Do not extrapolate.
4. Measuring procedure follows EN14511.
 - Rated values are based on standard conditions, and it can be found on specifications.
 - Above table values may not be matched according to installation condition. Except for rated value, the performance is not guaranteed.
 - In accordance with the test standard(or nations), the results may vary.
5. The Shaded areas are not guaranteed continuous operation.

6. Capacity Tables

6.1.2 Combination with IWT

◆ ZHUW056A0 [HU051MR U44] + ZHNW2060311 [HN0913T NK0]

Outdoor Temperature [°C DB]	Water flow rate 15.8 LPM													
	LWT 7 °C		LWT 10 °C		LWT 13 °C		LWT 15 °C		LWT 18 °C		LWT 20 °C		LWT 22 °C	
	TC	EER	TC	EER	TC	EER	TC	EER	TC	EER	TC	EER	TC	EER
10	5.50	4.57	5.50	4.85	5.50	5.13	5.50	5.31	5.50	5.59	5.50	5.78	5.50	5.96
20	5.50	3.86	5.50	4.23	5.50	4.61	5.50	4.86	5.50	5.23	5.50	5.48	5.50	5.74
30	5.50	3.15	5.50	3.62	5.50	4.09	5.50	4.41	5.50	4.88	5.50	5.19	5.50	5.51
35	5.50	2.80	5.50	3.32	5.50	3.84	5.50	4.18	5.50	4.60	5.50	5.05	5.50	5.39
40	5.32	2.45	5.34	2.84	5.35	3.24	5.37	3.50	5.38	3.90	5.40	4.17	5.41	4.43
45	5.13	2.09	5.17	2.37	5.21	2.64	5.23	2.83	5.27	3.10	5.29	3.29	5.32	3.47

◆ ZHUW076A0 [HU071MR U44] + ZHNW2060311 [HN0913T NK0]

Outdoor Temperature [°C DB]	Water flow rate 20.1 LPM													
	LWT 7 °C		LWT 10 °C		LWT 13 °C		LWT 15 °C		LWT 18 °C		LWT 20 °C		LWT 22 °C	
	TC	EER	TC	EER	TC	EER	TC	EER	TC	EER	TC	EER	TC	EER
10	7.00	4.37	7.00	4.64	7.00	4.91	7.00	5.09	7.00	5.35	7.00	5.53	7.00	5.71
20	7.00	3.70	7.00	4.06	7.00	4.42	7.00	4.66	7.00	5.01	7.00	5.25	7.00	5.49
30	7.00	3.03	7.00	3.48	7.00	3.93	7.00	4.22	7.00	4.67	7.00	4.97	7.00	5.27
35	7.00	2.70	7.00	3.19	7.00	3.68	7.00	4.01	7.00	4.50	7.00	4.83	7.00	5.15
40	6.50	2.37	6.63	2.74	6.81	3.11	7.00	3.36	7.00	3.74	7.00	3.99	7.00	4.24
45	6.43	2.03	6.48	2.29	6.63	2.55	6.66	2.72	6.70	2.98	6.74	3.15	6.77	3.32

◆ ZHUW096A0 [HU091MR U44] + ZHNW2060311 [HN0913T NK0]

Outdoor Temperature [°C DB]	Water flow rate 25.9 LPM													
	LWT 7 °C		LWT 10 °C		LWT 13 °C		LWT 15 °C		LWT 18 °C		LWT 20 °C		LWT 22 °C	
	TC	EER	TC	EER	TC	EER	TC	EER	TC	EER	TC	EER	TC	EER
10	9.00	4.08	9.00	4.33	9.00	4.58	9.00	4.75	9.00	5.00	9.00	5.16	9.00	5.33
20	9.00	3.49	9.00	3.81	9.00	4.14	9.00	4.35	9.00	4.68	9.00	4.89	9.00	5.11
30	9.00	2.90	9.00	3.30	9.00	3.69	9.00	3.96	9.00	4.36	9.00	4.63	9.00	4.89
35	9.00	2.60	9.00	3.04	9.00	3.47	9.00	3.76	9.00	4.20	9.00	4.49	9.00	4.61
40	8.10	2.30	8.10	2.63	8.70	2.96	9.00	3.18	9.00	3.50	9.00	3.72	9.00	3.94
45	7.50	2.01	7.70	2.23	7.80	2.44	7.90	2.59	8.00	2.81	8.10	2.95	8.20	3.10

Note

1. DB : Dry bulb temperature(°C), LWT : Leaving water temperature(°C), LPM : Liter per minute (ℓ/min)
2. TC : Total capacity(kW), EER: Energy efficiency ratio(kW/kW), COP : Coefficient of performance (kW/kW)
3. Direct interpolation is permissible. Do not extrapolate.
4. Measuring procedure follows EN14511.
 - Rated values are based on standard conditions, and it can be found on specifications.
 - Above table values may not be matched according to installation condition. Except for rated value, the performance is not guaranteed.
 - In accordance with the test standard(or nations), the results may vary.
5. The Shaded areas are not guaranteed continuous operation.

6. Capacity Tables

6.2 Heating Operation

6.2.1 Combination with Hydro Box type

■ Maximum Heating Capacity (Include defrost effect)

◆ ZHUW056A0 [HU051MR U44] + ZHNW09606A1 [HN091MR NK5]

Outdoor Temperature [°C DB]	Water flow rate 15.8 LPM								Water flow rate 9.9 LPM				Water flow rate 7.9 LPM			
	LWT 30 °C		LWT 35 °C		LWT 40 °C		LWT 45 °C		LWT 50 °C		LWT 55 °C		LWT 60 °C		LWT 65 °C	
	TC	COP	TC	COP	TC	COP	TC	COP	TC	COP	TC	COP	TC	COP	TC	COP
-25	4.02	1.96	3.90	1.84	3.78	1.72	3.66	1.60								
-20	4.64	2.59	4.51	2.07	4.38	1.90	4.26	1.74	4.13	1.57						
-15	5.26	2.51	5.12	2.30	4.99	2.09	4.85	1.88	4.72	1.66	4.58	1.45				
-7	5.50	2.88	5.50	2.70	5.50	2.53	5.50	2.35	5.50	2.18	5.50	2.00	5.50	1.83		
-4	5.50	3.18	5.50	2.97	5.50	2.75	5.50	2.53	5.50	2.31	5.50	2.10	5.50	1.88		
-2	5.50	3.41	5.50	3.14	5.50	2.88	5.50	2.61	5.50	2.34	5.50	2.08	5.50	1.81		
2	5.50	3.79	5.50	3.50	5.50	3.21	5.50	2.93	5.50	2.64	5.50	2.36	5.50	2.07	5.50	1.79
7	5.50	5.37	5.50	4.90	5.50	4.43	5.50	3.97	5.50	3.50	5.50	3.03	5.50	2.57	5.50	2.10
10	5.50	5.84	5.50	5.34	5.50	4.83	5.50	4.32	5.50	3.81	5.50	3.30	5.50	2.79	5.50	2.29
15	5.50	6.64	5.50	6.06	5.50	5.48	5.50	4.91	5.50	4.33	5.50	3.75	5.50	3.17	5.50	2.60
18	5.50	7.11	5.50	6.50	5.50	5.88	5.50	5.26	5.50	4.64	5.50	4.02	5.50	3.40	5.50	2.78
20	5.50	7.43	5.50	6.79	5.50	6.14	5.50	5.49	5.50	4.85	5.50	4.20	5.50	3.55	5.50	2.91
35	5.50	9.81	5.50	8.96	5.50	8.11	5.50	7.25	5.50	6.40	5.50	5.55	5.50	4.69	5.50	3.84

◆ ZHUW076A0 [HU071MR U44] + ZHNW09606A1 [HN091MR NK5]

Outdoor Temperature [°C DB]	Water flow rate 20.1 LPM								Water flow rate 12.6 LPM				Water flow rate 10.0 LPM			
	LWT 30 °C		LWT 35 °C		LWT 40 °C		LWT 45 °C		LWT 50 °C		LWT 55 °C		LWT 60 °C		LWT 65 °C	
	TC	COP	TC	COP	TC	COP	TC	COP	TC	COP	TC	COP	TC	COP	TC	COP
-25	5.00	1.95	4.85	1.78	4.71	1.62	4.56	1.45								
-20	5.58	2.52	5.43	2.02	5.27	1.84	5.11	1.66	4.95	1.49						
-15	6.17	2.44	6.00	2.25	5.83	2.06	5.66	1.88	5.49	1.69	5.32	1.50				
-7	7.00	2.76	7.00	2.72	7.00	2.44	7.00	2.28	7.00	2.11	7.00	2.06	7.00	1.79		
-4	7.00	3.07	7.00	2.87	7.00	2.66	7.00	2.45	7.00	2.24	7.00	2.08	7.00	1.83		
-2	7.00	3.27	7.00	3.04	7.00	2.82	7.00	2.59	7.00	2.37	7.00	2.14	7.00	2.06		
2	7.00	3.65	7.00	3.40	7.00	3.15	7.00	2.90	7.00	2.66	7.00	2.41	7.00	2.16	7.00	1.91
7	7.00	5.35	7.00	4.90	7.00	4.45	7.00	4.00	7.00	3.55	7.00	3.10	7.00	2.65	7.00	2.20
10	7.00	5.77	7.00	5.28	7.00	4.80	7.00	4.31	7.00	3.83	7.00	3.34	7.00	2.86	7.00	2.37
15	7.00	6.46	7.00	5.92	7.00	5.37	7.00	4.83	7.00	4.29	7.00	3.74	7.00	3.20	7.00	2.66
18	7.00	6.88	7.00	6.30	7.00	5.72	7.00	5.14	7.00	4.56	7.00	3.99	7.00	3.41	7.00	2.83
20	7.00	7.16	7.00	6.55	7.00	5.95	7.00	5.35	7.00	4.75	7.00	4.15	7.00	3.54	7.00	2.94
35	7.00	9.24	7.00	8.46	7.00	7.69	7.00	6.91	7.00	6.13	7.00	5.35	7.00	4.58	7.00	3.80

◆ ZHUW096A0 [HU091MR U44] + ZHNW09606A1 [HN091MR NK5]

Outdoor Temperature [°C DB]	Water flow rate 25.9 LPM								Water flow rate 16.2 LPM				Water flow rate 12.9 LPM			
	LWT 30 °C		LWT 35 °C		LWT 40 °C		LWT 45 °C		LWT 50 °C		LWT 55 °C		LWT 60 °C		LWT 65 °C	
	TC	COP	TC	COP	TC	COP	TC	COP	TC	COP	TC	COP	TC	COP	TC	COP
-25	6.40	1.85	6.20	1.70	6.00	1.55	5.80	1.40								
-20	7.23	2.45	7.00	1.96	6.77	1.80	6.54	1.64	6.31	1.48						
-15	8.06	2.39	7.80	2.22	7.54	2.05	7.28	1.89	7.02	1.72	6.76	1.55				
-7	9.00	2.75	9.00	2.71	9.00	2.35	9.00	2.20	9.00	2.05	9.00	1.90	9.00	1.75		
-4	9.00	2.98	9.00	2.78	9.00	2.58	9.00	2.38	9.00	2.18	9.00	1.98	9.00	1.78		
-2	9.00	3.16	9.00	2.97	9.00	2.78	9.00	2.59	9.00	2.40	9.00	2.21	9.00	2.02		
2	9.00	3.57	9.00	3.35	9.00	3.13	9.00	2.91	9.00	2.69	9.00	2.47	9.00	2.25	9.00	2.04
7	9.00	5.04	9.00	4.65	9.00	4.26	9.00	3.87	9.00	3.48	9.00	3.08	9.00	2.69	9.00	2.30
10	9.00	5.39	9.00	4.97	9.00	4.55	9.00	4.13	9.00	3.71	9.00	3.30	9.00	2.88	9.00	2.46
15	9.00	5.97	9.00	5.50	9.00	5.04	9.00	4.58	9.00	4.11	9.00	3.65	9.00	3.19	9.00	2.72
18	9.00	6.32	9.00	5.83	9.00	5.33	9.00	4.84	9.00	4.35	9.00	3.86	9.00	3.37	9.00	2.88
20	9.00	6.55	9.00	6.04	9.00	5.53	9.00	5.02	9.00	4.51	9.00	4.00	9.00	3.50	9.00	2.99
35	9.00	8.29	9.00	7.64	9.00	7.00	9.00	6.35	9.00	5.71	9.00	5.07	9.00	4.42	9.00	3.78

Note

1. DB : Dry bulb temperature(°C), LWT : Leaving water temperature(°C), LPM : Liter per minute (ℓ/min)
2. TC : Total capacity(kW), EER: Energy efficiency ratio(kW/kW), COP : Coefficient of performance (kW/kW)
3. Direct interpolation is permissible. Do not extrapolate.
4. Measuring procedure follows EN14511.
 - Rated values are based on standard conditions, and it can be found on specifications.
 - Above table values may not be matched according to installation condition. Except for rated value, the performance is not guaranteed.
 - In accordance with the test standard(or nations), the results may vary.
5. The Shaded areas are not guaranteed continuous operation.

6. Capacity Tables

6.2.2 Combination with IWT

■ Maximum Heating Capacity (Include defrost effect)

◆ ZHUW056A0 [HU051MR U44] + ZHNW2060311 [HN0913T NK0]

Outdoor Temperature [°C DB]	Water flow rate 15.8 LPM								Water flow rate 9.9 LPM				Water flow rate 7.9 LPM			
	LWT 30 °C		LWT 35 °C		LWT 40 °C		LWT 45 °C		LWT 50 °C		LWT 55 °C		LWT 60 °C		LWT 65 °C	
	TC	COP	TC	COP	TC	COP	TC	COP	TC	COP	TC	COP	TC	COP	TC	COP
-25	4.02	1.96	3.90	1.84	3.78	1.72	3.66	1.60								
-20	4.64	2.59	4.51	2.07	4.38	1.90	4.26	1.74	4.13	1.57						
-15	5.26	2.51	5.12	2.30	4.99	2.09	4.85	1.88	4.72	1.66	4.58	1.45				
-7	5.50	2.88	5.50	2.70	5.50	2.53	5.50	2.35	5.50	2.18	5.50	2.00	5.50	1.83		
-4	5.50	3.18	5.50	2.97	5.50	2.75	5.50	2.53	5.50	2.31	5.50	2.10	5.50	1.88		
-2	5.50	3.41	5.50	3.14	5.50	2.88	5.50	2.61	5.50	2.34	5.50	2.08	5.50	1.81		
2	5.50	3.79	5.50	3.50	5.50	3.21	5.50	2.93	5.50	2.64	5.50	2.36	5.50	2.07	5.50	1.79
7	5.50	5.37	5.50	4.90	5.50	4.43	5.50	3.97	5.50	3.50	5.50	3.03	5.50	2.57	5.50	2.10
10	5.50	5.84	5.50	5.34	5.50	4.83	5.50	4.32	5.50	3.81	5.50	3.30	5.50	2.79	5.50	2.29
15	5.50	6.64	5.50	6.06	5.50	5.48	5.50	4.91	5.50	4.33	5.50	3.75	5.50	3.17	5.50	2.60
18	5.50	7.11	5.50	6.50	5.50	5.88	5.50	5.26	5.50	4.64	5.50	4.02	5.50	3.40	5.50	2.78
20	5.50	7.43	5.50	6.79	5.50	6.14	5.50	5.49	5.50	4.85	5.50	4.20	5.50	3.55	5.50	2.91
35	5.50	9.81	5.50	8.96	5.50	8.11	5.50	7.25	5.50	6.40	5.50	5.55	5.50	4.69	5.50	3.84

◆ ZHUW076A0 [HU071MR U44] + ZHNW2060311 [HN0913T NK0]

Outdoor Temperature [°C DB]	Water flow rate 20.1 LPM								Water flow rate 12.6 LPM				Water flow rate 10.0 LPM			
	LWT 30 °C		LWT 35 °C		LWT 40 °C		LWT 45 °C		LWT 50 °C		LWT 55 °C		LWT 60 °C		LWT 65 °C	
	TC	COP	TC	COP	TC	COP	TC	COP	TC	COP	TC	COP	TC	COP	TC	COP
-25	5.00	1.95	4.85	1.78	4.71	1.62	4.56	1.45								
-20	5.58	2.52	5.43	2.02	5.27	1.84	5.11	1.66	4.95	1.49						
-15	6.17	2.38	6.00	2.25	5.83	2.06	5.66	1.88	5.49	1.69	5.32	1.50				
-7	7.00	2.76	7.00	2.72	7.00	2.44	7.00	2.28	7.00	2.11	7.00	2.06	6.49	1.79		
-4	7.00	3.07	7.00	2.87	7.00	2.66	7.00	2.45	7.00	2.24	7.00	2.08	7.00	1.83		
-2	7.00	3.27	7.00	3.04	7.00	2.82	7.00	2.59	7.00	2.37	7.00	2.14	7.00	2.06		
2	7.00	3.65	7.00	3.40	7.00	3.15	7.00	2.90	7.00	2.66	7.00	2.41	7.00	2.16	7.00	1.91
7	7.00	5.35	7.00	4.90	7.00	4.45	7.00	4.00	7.00	3.55	7.00	3.10	7.00	2.65	7.00	2.20
10	7.00	5.77	7.00	5.28	7.00	4.80	7.00	4.31	7.00	3.83	7.00	3.34	7.00	2.86	7.00	2.37
15	7.00	6.46	7.00	5.92	7.00	5.37	7.00	4.59	7.00	3.97	7.00	3.74	7.00	3.20	7.00	2.66
18	7.00	6.88	7.00	6.30	7.00	5.72	7.00	4.78	7.00	4.17	7.00	3.99	7.00	3.41	7.00	2.83
20	7.00	7.16	7.00	6.55	7.00	5.95	7.00	4.90	7.00	4.32	7.00	4.15	7.00	3.54	7.00	2.94
35	7.00	8.86	7.00	7.79	7.00	6.57	7.00	5.82	7.00	5.32	7.00	4.92	7.00	4.58	7.00	3.80

◆ ZHUW096A0 [HU091MR U44] + ZHNW2060311 [HN0913T NK0]

Outdoor Temperature [°C DB]	Water flow rate 25.9 LPM								Water flow rate 16.2 LPM				Water flow rate 12.9 LPM			
	LWT 30 °C		LWT 35 °C		LWT 40 °C		LWT 45 °C		LWT 50 °C		LWT 55 °C		LWT 60 °C		LWT 65 °C	
	TC	COP	TC	COP	TC	COP	TC	COP	TC	COP	TC	COP	TC	COP	TC	COP
-25	6.40	1.85	6.20	1.70	6.00	1.55	5.80	1.40								
-20	7.23	2.45	7.00	1.96	6.77	1.80	6.54	1.64	6.31	1.48						
-15	8.06	2.39	7.80	2.22	7.54	2.05	7.28	1.89	7.02	1.72	7.10	1.55				
-7	9.00	2.75	9.00	2.71	9.00	2.35	9.00	2.20	9.00	2.05	9.00	1.90	8.60	1.75		
-4	9.00	2.98	9.00	2.78	9.00	2.58	9.00	2.38	9.00	2.18	9.00	1.98	9.00	1.78		
-2	9.00	3.16	9.00	2.97	9.00	2.78	9.00	2.59	9.00	2.40	9.00	2.21	9.00	2.02		
2	9.00	3.57	9.00	3.35	9.00	3.13	9.00	2.91	9.00	2.69	9.00	2.47	9.00	2.25	9.00	2.04
7	9.00	5.04	9.00	4.65	9.00	4.26	9.00	3.87	9.00	3.34	9.00	2.98	9.00	2.61	9.00	2.30
10	9.00	5.39	9.00	4.97	9.00	4.55	9.00	4.09	9.00	3.51	9.00	3.16	9.00	2.79	9.00	2.46
15	9.00	5.97	9.00	5.50	9.00	5.04	9.00	4.35	9.00	3.80	9.00	3.44	9.00	3.07	9.00	2.72
18	9.00	6.32	9.00	5.83	9.00	5.33	9.00	4.50	9.00	3.98	9.00	3.60	9.00	3.23	9.00	2.88
20	9.00	6.55	9.00	6.04	9.00	5.53	9.00	4.60	9.00	4.10	9.00	3.70	9.00	3.35	9.00	2.99
35	9.00	8.29	9.00	7.64	9.00	6.50	9.00	5.35	9.00	4.96	9.00	4.58	9.00	4.19	7.95	3.78

Note

1. DB : Dry bulb temperature(°C), LWT : Leaving water temperature(°C), LPM : Liter per minute (ℓ/min)
2. TC : Total capacity(kW), EER: Energy efficiency ratio(kW/kW), COP : Coefficient of performance (kW/kW)
3. Direct interpolation is permissible. Do not extrapolate.
4. Measuring procedure follows EN14511.
 - Rated values are based on standard conditions, and it can be found on specifications.
 - Above table values may not be matched according to installation condition. Except for rated value, the performance is not guaranteed.
 - In accordance with the test standard(or nations), the results may vary.
5. The Shaded areas are not guaranteed continuous operation.

7. Wiring Diagram

Internal Diagrams

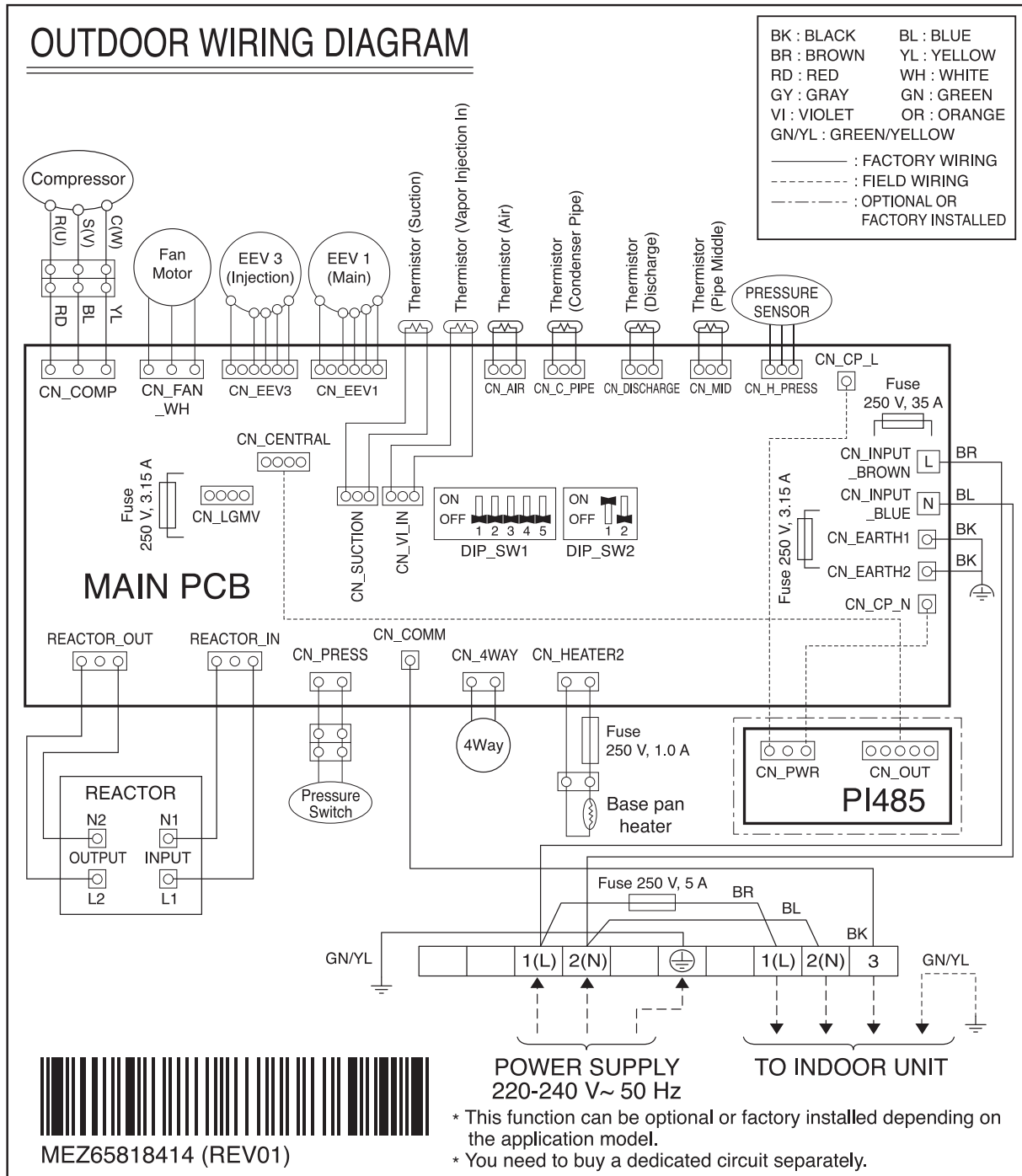

7. Wiring Diagram

Field Wiring

◆ For Hydro Box type

[Power Supply for Heat Pump]

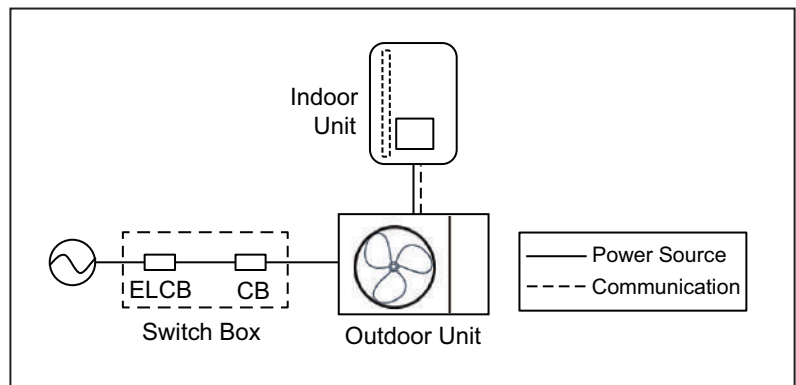

[Power Supply for Backup Heater]

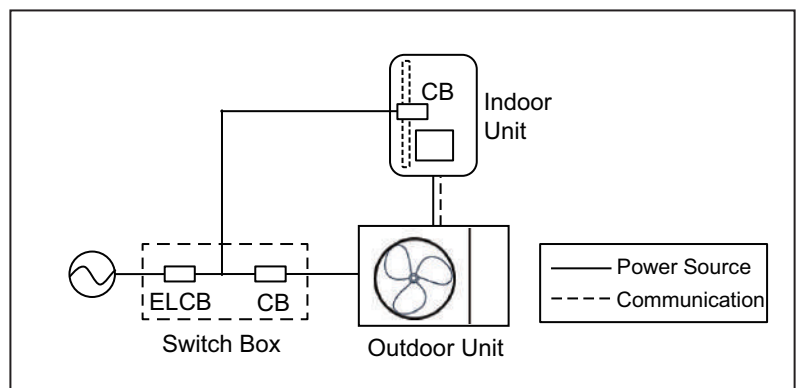

[Power Supply for DHW Boost Heater]

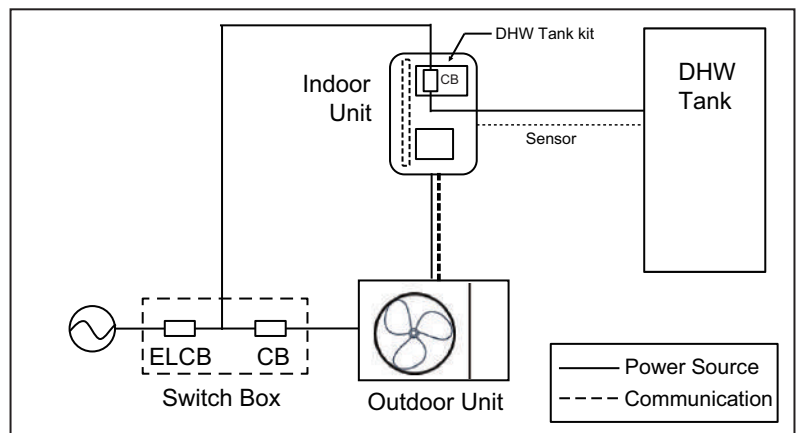

Note

1. Voltage supplied to the unit terminals should be within the minimum and maximum range.
2. Maximum allowable voltage unbalance between phase is 2%.
3. All installation site must require attachment of an earth leakage breaker. [circuit breaker type is ELCB(Earth Leakage Circuit Breaker)].

7. Wiring Diagram

◆ For IWT

[Power Supply for Heat pump and 1Φ Electric heater]

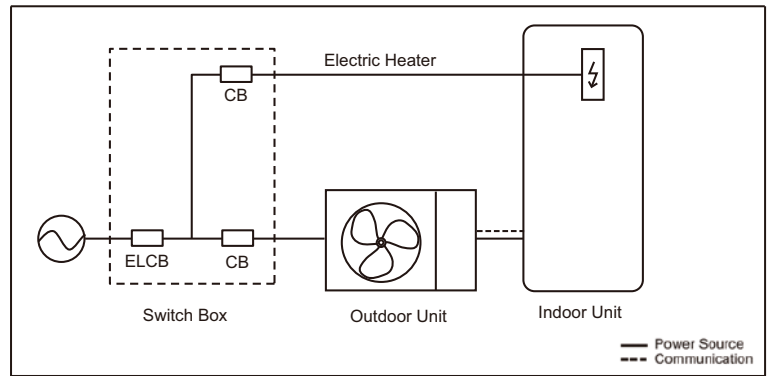

Note

1. Voltage supplied to the unit terminals should be within the minimum and maximum range.
2. Maximum allowable voltage unbalance between phase is 2%.
3. All installation site must require attachment of an earth leakage breaker. [circuit breaker type is ELCB(Earth Leakage Circuit Breaker)].

8. Operation Limits

8.1 Cooling

◆ Fan Coil unit : Used

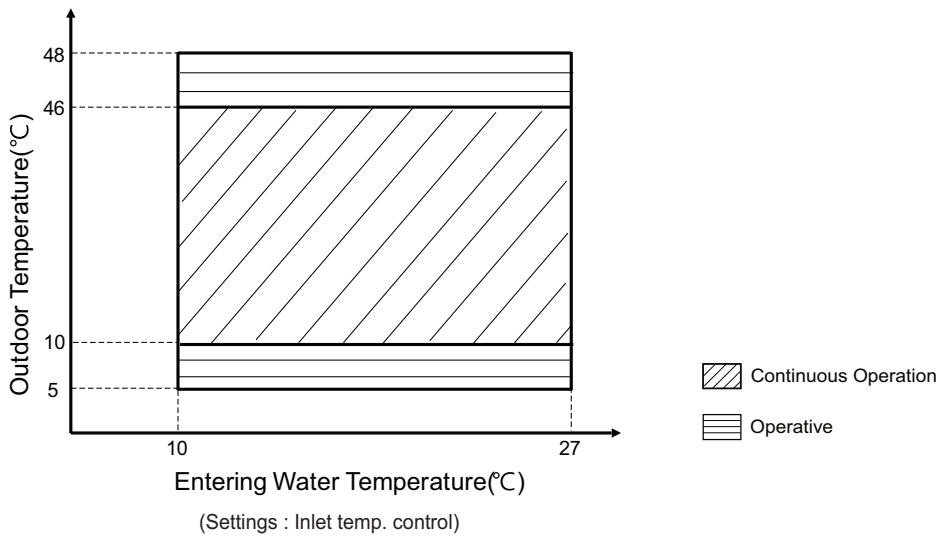
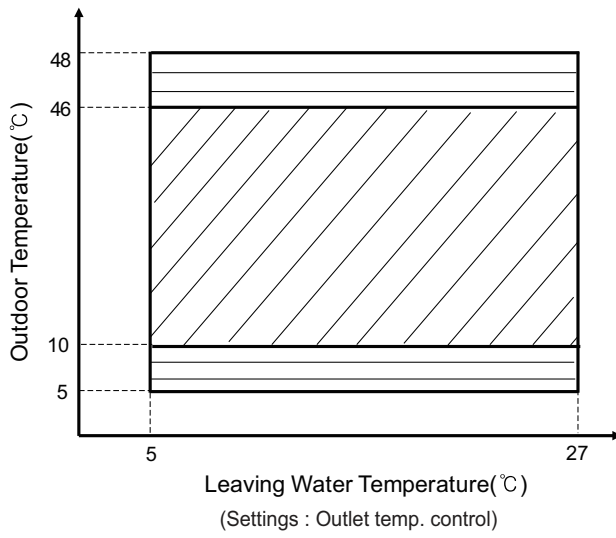

Note

- Continuous Operation : It is possible to operate continuously, but capacity is not guaranteed.
- Operative : It is not guaranteed continuous operation.

8. Operation Limits

◆ Fan Coil unit : not Used

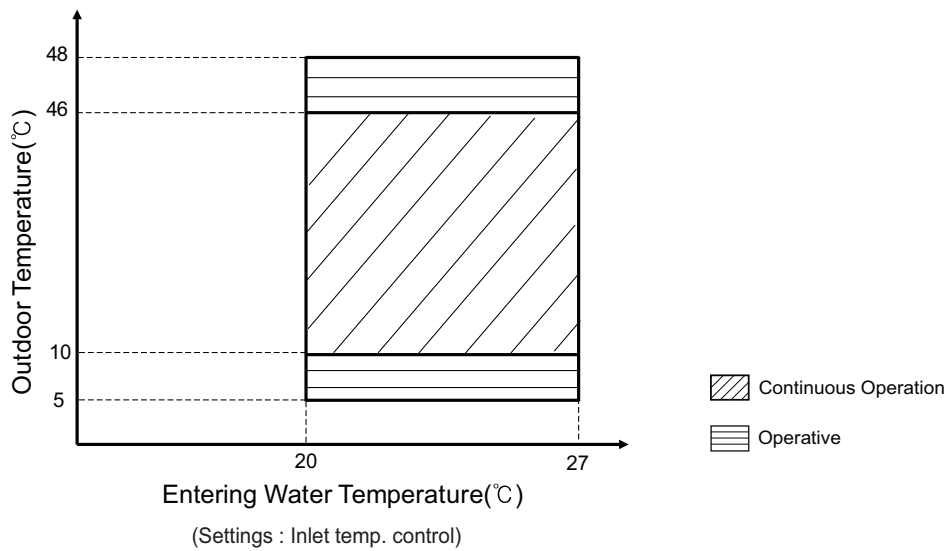
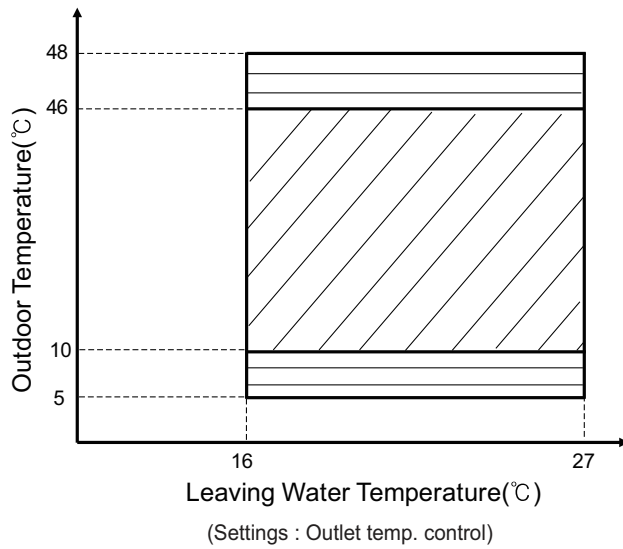

Note

- Continuous Operation : It is possible to operate continuously, but capacity is not guaranteed.
- Operative : It is not guaranteed continuous operation.

8. Operation Limits

8.2 Heating

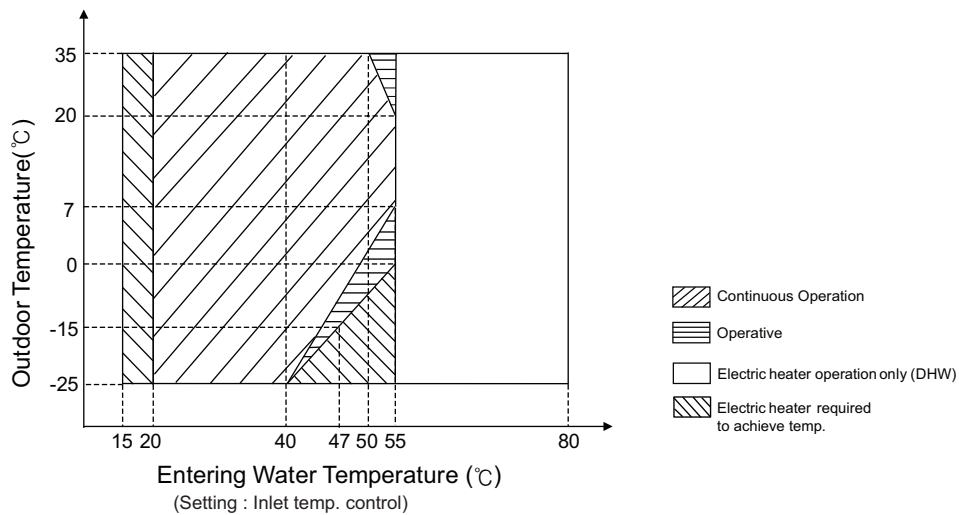
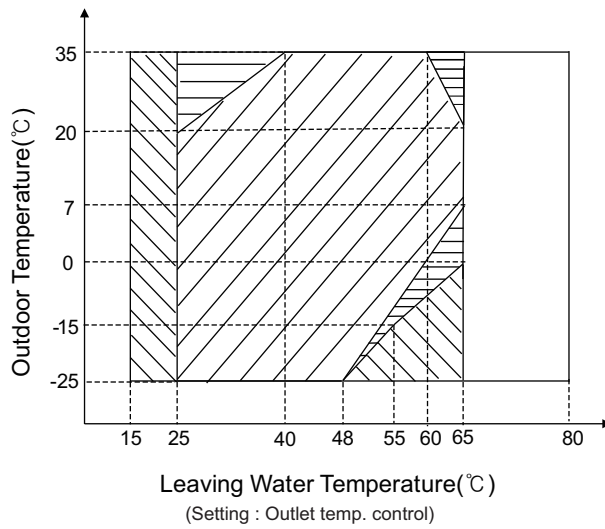

Note

- Continuous Operation : It is possible to operate continuously, but capacity is not guaranteed.
- Operative : It is not guaranteed continuous operation.
- DHW operation : max. 58 °C
- DHW operation with Electric heater : max. 80 °C

9. Sound levels

9.1 Sound Power Level

Note

1. Data is valid at diffuse field condition.
2. Reference acoustic intensity $0\text{dB} = 10\text{E-}6\mu\text{W}/\text{m}^2$
3. Sound power level is measured on the rated condition in the reverberation rooms. Refer to the Model Specifications for nominal conditions(Power source and Ambient temperature, etc)
4. Sound levels can be increased in accordance with installation and operating conditions.
5. Sound level will vary depending on a range of factors such as the construction (acoustic absorption coefficient) of particular installed place in which the equipment in installed.
6. Sound power level is measured on the rated condition in accordance with ISO 9614 standard. Therefore, these values can be increased owing to ambient conditions during operation.

Model		Sound Power Level [dB(A)]	
		Heating	
Indoor Unit	Outdoor Unit	Rated	Low Noise
ZHNW09606A1 [HN091MR NK5]	ZHUW056A0 [HU051MR U44]	60	58
	ZHUW076A0 [HU071MR U44]	60	58
	ZHUW096A0 [HU091MR U44]	60	58
ZHNW20603I1 [HN0913T NK0]	ZHUW056A0 [HU051MR U44]	60	58
	ZHUW076A0 [HU071MR U44]	60	58
	ZHUW096A0 [HU091MR U44]	60	58

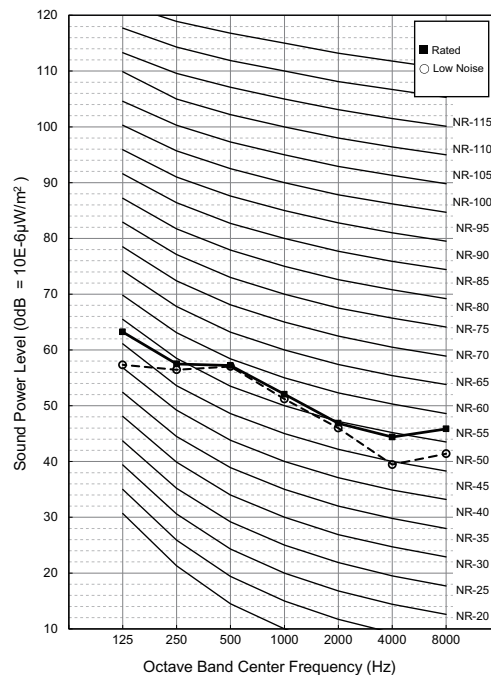

THERMA VTM

Split Type

Design and installation

- 1.Refrigerant R32**
- 2.Select the Best Location**
- 3.Installation Space**
- 4.Water Control**
- 5.Dip Switch Setting**

1. Refrigerant R32

The refrigerant R32 has the higher efficiency and more friendly for environment in comparison with R410A. It has a lower GWP (Global Warming Potential) value, and higher efficiency than R410A. The Ozone Depletion Potential (ODP) of R32 is 0, and Global Warming Potential(GWP) is 675.

Refrigerant piping consists of copper/steel pipes, joints, and other fittings. All components must be selected and installed in conformity with the standards pertaining to the Refrigeration Safety Regulation. Same piping as for R410A can be used.

WARNING

- This product contains fluorinated greenhouse gases (Refrigerant type : R32). Do NOT emit refrigerant gases into the atmosphere.
 - The refrigerant R32 is Slightly Flammable gas. But it does not leak normally. If the refrigerant leaks in the installed place and contact with burning energy, it may cause fire, or a harmful gas.
 - If there are some leak, turn off any combustible devices, ventilate the installed place, and contact the dealer from which you purchased the unit. Do not use the unit until the refrigerant leaked is repaired.
 - Only use R32 as refrigerant. Other substances may cause explosions and accidents.
-

CAUTION

- The wall thickness of the piping should comply with the relevant local and national regulations for the designed pressure.
 - For high-pressure refrigerant, any unapproved pipe must not be used.
 - Do not heat pipes more than necessary to prevent them from softening.
-

2. Select the Best Location

Select space for installing unit, which will meet the following conditions:

- No direct thermal radiation from other heat sources
- No possibility of annoying neighbors by noise from unit
- No exposition to strong wind
- With strength which bears weight of unit
- With space for air passage and service work shown next
- Because of the possibility of fire, do not install unit to the space where generation, inflow, stagnation, and leakage of combustible gas is expected.
- Avoid unit installation in a place where acidic solution and spray (sulfur) are often used.
- Do not use unit under any special environment where oil, steam and sulfuric gas exist.
- It is recommended to fence round the unit in order to prevent any person or animal from accessing the unit.
- If installation site is area of heavy snowfall, then the following directions should be observed.
 - Make the foundation as high as possible.
 - Fit a snow protection hood.
- Select installation location considering following conditions to avoid bad condition when additionally performing defrost operation.
 1. Install the unit at a place well ventilated and having a lot of sunshine in case of installing the product at a place with a high humidity in winter (near beach, coast, lake, etc).
 2. Performance of heating will be reduced and pre-heat time of the unit may be lengthened in case of installing the unit in winter at following location:
 - 1) Shade position with a narrow space
 - 2) Location with much humidity around.
 - 3) Location where liquid gathers since the floor is not even.
- When installing the unit in a place that is constantly exposed to a strong wind like a coast or on a high story of a building, secure a normal fan operation by using a duct or a wind shield.
 1. Install the unit so that its discharge port faces to the wall of the building. Keep a distance 300 mm or more between the unit and the wall surface.
 2. Supposing the wind direction during the operation season of the unit, install the unit so that the discharge port is set at right angle to the wind direction.

3. Installation Space

3.1 Clearance around outdoor units

- Ensure that the space around the back is or more more than 300 mm on the opposite to the PCB side and secure 600 mm space near the compressor and PCB side of the air conditioner for service.

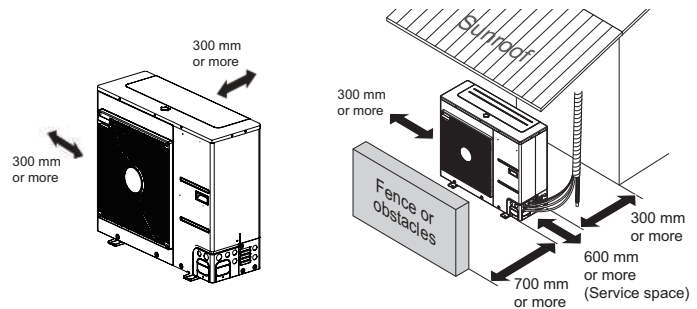

※ Outdoor unit is representative. Actual appearance of outdoor unit may be different but clearances will stay the same.

- Install the unit so that its discharge port faces to the wall of the building. Keep a distance 500mm or more between the unit and the wall surface.
- Supposing the wind direction during the operation season of the air conditioner, install the unit so that the discharge port is set at right angle to the wind direction.

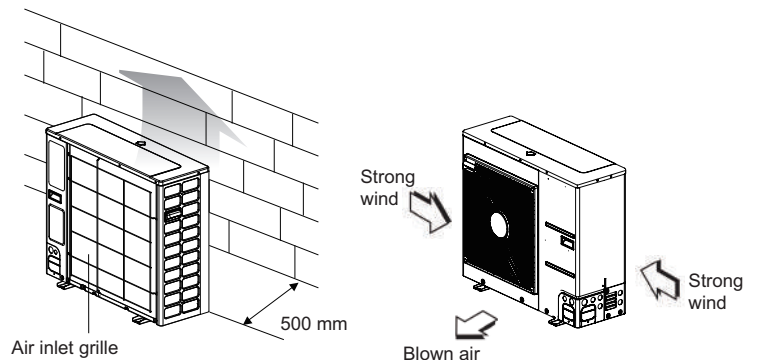

Turn the air outlet side toward the building's wall, fence or windbreak screen.

Set the outlet side at a right angle to the direction of the wind.

※ Outdoor unit is representative. Actual appearance of outdoor unit may be different but clearances will stay the same.

4. Water Control

4.1 Water quality

Water quality should be complied with EN 98/83 EC Directives.

CAUTION

- If the product is installed at existing hydraulic water loop, it is important to clean hydraulic pipes to remove sludge and scale.
- Installing sludge strainer in the water loop is very important to prevent performance degrade.
- Chemical treatment to prevent rust should be performed by installer.
- It is strongly recommended to install an additional filter on the heating water circuit. Especially to remove metallic particles from the heating piping, it is advised to use a magnetic or cyclone filter, which can remove small particles. Small particles may damage the unit and will NOT be removed by the standard filter of the heat pump system.
- Water quality check should be implemented before completing the installation of system.
Detailed guide can be found in the table as below.

Water contents	Value			
pH	7.5~9.0			
Conductivity	10~500 uS/cm			
TDS (Total dissolved solids)	8~400 ppm			
Alkalinity (HCO ₃ ⁻)	60~300 (mg/L)			
Total hardness	4 ~ 8.5 °dH			
	71.4 ~ 151.7 (mg/L)			
Iron (Fe)	≤ 0.2 (mg/L)			
Sulphate (SO ₄ ²⁻)	≤ 100 (mg/L)			
Nitrite (NO ₃ ⁻)	≤ 100 (mg/L)			
Free chlorine (Cl ₂)	≤ 1 (mg/L)			
Chlorides (Cl ⁻)	ppm		STS316	STS304
	pH7	15 °C	3,000	180
		40 °C	500	50
		60 °C	200	30
		80 °C	125	20
	pH9	15 °C	18,000	700
		40 °C	2,600	250
		60 °C	1,000	170
80 °C		550	130	

4. Water Control

4.2 Frost protection

In areas of the country where entering water temperatures drop below 0 °C, the water pipe must be protected by using an approved antifreeze solution. Consult your heat pump unit supplier for locally approved solutions in your area.

Calculate the approximate volume of water in the system. And add the water volume contained in the heat pump to this total volume.

Antifreeze type	Antifreeze mixing ratio (by volume)					
	0°C	-5°C	-10°C	-15°C	-20°C	-25°C
Methanol	0%	6%	12%	16%	24%	30%
Ethylene glycol	0%	12%	20%	30%	-	-
Propylene glycol	0%	17%	25%	33%	-	-

CAUTION

- Use only one of the above antifreeze.
- If a antifreeze is used, pressure drop and capability degradation of the system can be occurred.
- If one of antifreezes is used, corrosion can be occurred. So please add corrosion inhibitor.
- Please check the concentration of the antifreeze periodically to keep same concentration.
- When the antifreeze is used (for installation or operation), take care to ensure that antifreeze must not be touched.
- Ensure to respect all laws and norms of your country about antifreeze usage.

4. Water Control

4.3 Capacity correction factor by antifreeze

Antifreeze Type	Item	Antifreeze % by wt				
		10%	20%	30%	40%	50%
Methanol	Cooling	0.998	0.997	0.995	0.993	0.992
	Heating	0.995	0.990	0.985	0.979	0.974
	Pressure Drop	1.023	1.057	1.091	1.122	1.160
Ethylene glycol	Cooling	0.996	0.991	0.987	0.983	0.979
	Heating	0.993	0.985	0.977	0.969	0.961
	Pressure Drop	1.024	1.068	1.124	1.188	1.263
Propylene glycol	Cooling	0.993	0.987	0.980	0.974	0.968
	Heating	0.966	0.973	0.960	0.948	0.935
	Pressure Drop	1.040	1.098	1.174	1.273	1.405

◆ Correction factor of cooling capacity

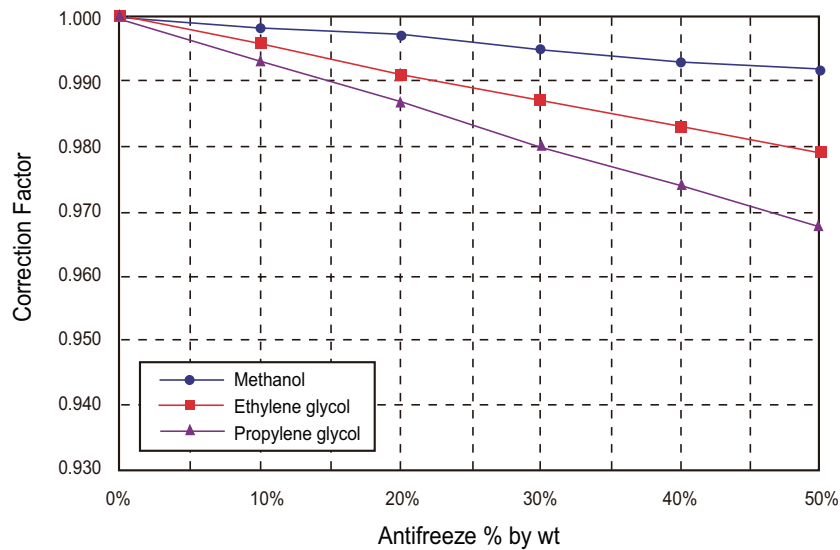

◆ Correction factor of heating capacity

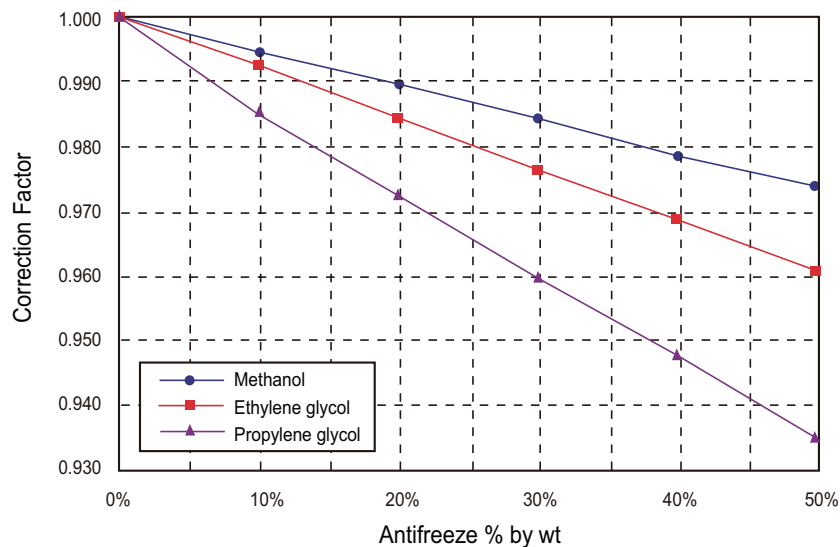

5. Dip Switch Setting

5.1 Information

Turn off electric power supply before setting DIP switch

- Whenever adjusting DIP switch, turn off electric power supply to avoid electric shock.

Indoor PCB

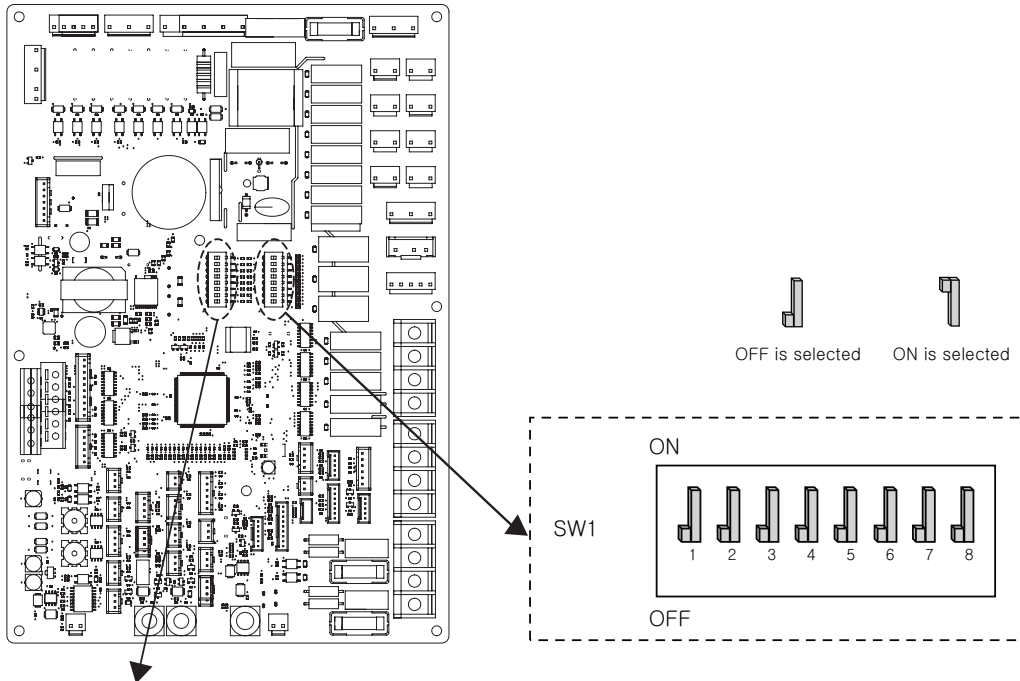

◆ Hydro Box type

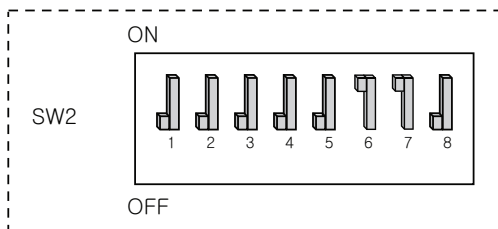

◆ IWT

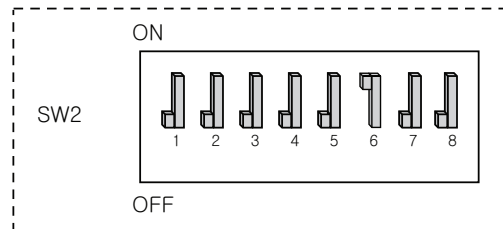

◆ Dip switch SW1

































Description	Setting	Default
MODBUS Communication Type	1 As Master (LG extension modules)	1
	1 As Slave (3rd party controller)	
MODBUS Function	2 REGIN	2
	2 Unified Open Modbus protocol	
ANTIFREEZE	8 Antifreeze agent is not used	8
	8 Antifreeze agent in used*	

* Possibility to allow colder water temperature by setting.

Bridge at CN_FLOW2 on Hydro-PCB must be dis-connected to enable setting.































5. Dip Switch Setting

◆ Dip switch SW2 (for Hydro Box Type)

Description	Setting	Default
Group control	1  As Master	1 
	1  As Slave	
Accessory installation information	  Heat pump is installed (Heating(Cooling) circuit only)	2  3 
	  Heat pump + DHW tank is installed	
	  Heat pump + DHW tank + Solar thermal system is installed	
	  Unused	
Cycle	4  Heating Only	4 
	4  Heating & Cooling	
Room Air Sensor	5  Room Air Sensor is not installed	5 
	5  Room Air Sensor is installed	
Selecting Backup Heater capacity	  Electric Heater is not used	6  7 
	  Half capacity is used	
	  Unused	
	  Full capacity is used	
Thermostat installation information	8  Thermostat is NOT installed	8 
	8  Thermostat is installed	

5. Dip Switch Setting

◆ Dip switch SW2 (for IWT)

Description	Setting	Default
Group control	1  As Master	1 
	1  As Slave	
Accessory installation information	  2 3 Unit + Outdoor unit + DHW tank is installed	2  3 
	  2 3 Unused	
	  2 3 Unused	
Cycle	4  Heating Only	4 
	4  Heating & Cooling	
Room Air Sensor	5  Room Air Sensor is not installed	5 
	5  Room Air Sensor is installed	
Selecting Backup Heater capacity	  6 7 Electric Heater is not used	6  7 
	  6 7 Full capacity is used	
	  6 7 Electric Heater is not used	
	  6 7 Electric Heater is not used	
Thermostat installation information	8  Thermostat is NOT installed	8 
	8  Thermostat is installed	

5. Dip Switch Setting

Outdoor Unit

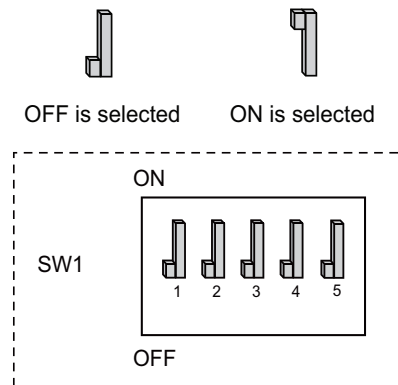

◆ Dip switch Information

Description	Setting		Default	
Low Noise Mode	2	OFF	Always Mode : Maintain Low noise mode for target temperature	OFF
		ON	Partial mode : Escape Low noise mode for target temperature	
Peak Control	3	OFF	Max Mode	
		ON	Peak Control : To limit maximum current (Power saving)	

- Only DIP-switch no. 2 and no.3 has a function. Others have no function.
- When setting the Partial mode, mode can be exited to secure capacity after operating for a certain time.



Air Solution

LG Electronics Inc, 128, Yeoui-daero,
Yeongdeungpo-gu, Seoul, Korea
(07336)

<http://partner.lge.com>

<http://sedc.lge.com>

Copyright © 2022 LG Electronics Inc.
All Rights Reserved.

The air conditioners manufactured by LG have received ISO9001 certificate for quality assurance and ISO14001 certificate for environmental management system.
The specifications, designs, and information in this brochure are subject to change without notice.